

# TRUCK CRANE

## TG-450M

TG

### *JAPANESE SPECIFICATIONS*

CARRIER MODEL	OUTLINE	SPEC. NO.
NISSAN DIESEL K-KG54T	5-section Boom, 2-stage Jib	TG-450M-3-10101
MITSUBISHI P-K450		TG-450M-3-20101

Control No. JA-01

# TG-450M

## CRANE SPECIFICATIONS

### CRANE CAPACITY

10.65m Boom	45,000kg	at 3.0m	(11 part-line)
18.0m Boom	28,000kg	at 5.0m	( 7 part-line)
25.3m Boom	20,000kg	at 6.0m	( 5 part-line)
32.7m Boom	13,000kg	at 7.5m	( 4 part-line)
40.0m Boom	7,500kg	at 10.0m	( 2 part-line)
9.0m Jib	3,500kg	at 78°	( 1 part-line)
16.0m Jib	2,300kg	at 78°	( 1 part-line)
Single top	4,000kg		( 1 part-line)

### MAX. LIFTING HEIGHT

Boom	39.5m
Jib	55.5m

### MAX. WORKING RADIUS

Boom	30.0m (Standard)
	34.0m (With device for heavy-duty work)
Jib	36.5m (Standard)
	39.3m (With device for heavy-duty work)

### BOOM LENGTH

10.65m – 40.0m

### BOOM EXTENSION

29.35m

### BOOM EXTENSION SPEED

29.35m / 120s

### JIB LENGTH

9.0m, 16.0m

### MAIN WINCH SINGLE LINE SPEED

High range:	100m/min	(3rd layer)
Low range:	45m/min	(3rd layer)

### MAIN WINCH HOOK SPEED

High range:	9.0m/min	(11 part-line)
Low range:	4.0m/min	(11 part-line)

### AUXILIARY WINCH SINGLE LINE SPEED

High range:	93m/min	(2nd layer)
Low range:	42m/min	(2nd layer)

### AUXILIARY WINCH HOOK SPEED

High range:	93m/min	(1 part-line)
Low range:	42m/min	(1 part-line)

### BOOM ELEVATION ANGLE

-3° – 80°

### BOOM ELEVATION SPEED

-3° – 80° / 68s

### SWING ANGLE

360° continue

### SWING SPEED

2.0 rpm

### WIRE ROPE

Main Winch

18mm × 185m (Diameter × Length)  
7×7+6×Fi(29) Class C ordinary · Z twist  
Spin-resistant wire rope  
Breaking strength 24.3t

Auxiliary Winch

18mm × 130m (Diameter × Length)  
7×7+6×Fi(29) Class B ordinary · Z twist  
Spin-resistant wire rope  
Breaking strength 22.3t

### BOOM

5-section power telescoping boom of hexagonal box construction

(stages 2,3: synchronized; stage 4,5: synchronized)

### BOOM EXTENSION

3 double-acting hydraulic cylinder

1 wire rope type telescoping device

### JIB

2-staged swingaround boom extensions.  
(stages 2: pull-out type)  
Triple offset (5°, 25°, 45°) type

### SINGLE TOP

Single sheave. Mounted to main boom head for single line work.

### HOIST

Hydraulic motor driven planetary gear reducer.  
With free-fall device.  
Automatic brake (with foot brake for free-fall device)  
2 single winches

### BOOM ELEVATION

2 double-acting hydraulic cylinders

### SWING

Hydraulic motor driven planetary gear reducer  
Swing bearing  
Hand brake  
Swing free/lock changeover type

### OUTRIGGERS

Fully hydraulic H-type (Floats mounted integrally)  
Slides and jacks each provided with independent operation device.

Full extended width 6.8m  
Middle extended width 4.6m

### FRONT JACK

Hydraulic operated type

### MAX. OUTRIGGER LOAD

44.0t

### HYDRAULIC PUMPS

4 gear pumps

### HYDRAULIC OIL TANK CAPACITY

675liters

### SAFETY DEVICES

Automatic moment limiter (AML)  
With working range limiting function  
Over-winding cutout

Level gauge

Working area control device

Hook safety latch

Cable follower

Winch drum lock

Winch drum rotation indicator

Hydraulic safety valve

Telescopic counterbalance valve

Elevation counterbalance valve

Jack pilot check valve

Front jack over load alarm

### EQUIPMENTS

Crane cab heater

Oil cooler

Boom angle indicator

Radio

Fan

Block

### OPTIONAL EQUIPMENT

Device for heavy-duty work

## CARRIER SPECIFICATIONS

### MANUFACTURER

NISSAN DIESEL MOTOR CO., LTD

### CARRIER MODEL

P-KG54T

### ENGINE

Model RF8

Type 4-cycle V8-cylinder, direct-injection, water-cooled diesel engine

Piston displacement 16,991cc

Max. output 340PS at 2,200rpm

Max. torque 120kg·m at 1,200rpm

### CLUTCH

Dry single-plate coil spring type

### TRANSMISSION

7-forward and 1-reverse speeds

Synchronized-mesh gear (for 2nd - 7th speeds)

### REDUCER

Hypoid gear type

### FRONT AXLE

Reverse Elliot-type steel pipe cross section  
(with stabilizers on front and rear axles)

### REAR AXLE

Full floating, cast torque rods

### SUSPENSION

Front Laminated leaf spring type

Rear Equalizer and torque rods

### STEERING

Recirculating ball screw type with linkage power assistance

### BRAKE SYSTEM

Service Brake

2-circuit air brake, 8-wheels internal expanding brake

Parking Brake

Mechanically operated, duo-servo shoe type acting on drum at transmission case rear.

Auxiliary Brake

Electro-pneumatic operated exhaust brake

Emergency

Spring brake

### ELECTRIC SYSTEM

24 V DC. 2 batteries of 12V-115F51 (96Ah)

### FUEL TANK CAPACITY

300 liters

### CAB

Two-man type

### TIRES

Front 13.00-20-20PR

Rear 11.00-20-14PR

### STANDARD EQUIPMENTS

Car heater

Car radio

## GENERAL DATA

### DIMENSIONS

Overall length 12,840mm

Overall width 2,820mm

Overall height 3,750mm

Wheel base 1,470mm + 3,780mm + 1,400mm = 6,650mm

Tread Front 2,230mm

Rear 2,110mm

### WEIGHTS

Gross vehicle weight

Total 37,230kg

Front 16,320kg

Rear 20,910kg

### PERFORMANCE

Max. traveling speed 65km/h

Min. traveling speed 1.2km/h

Gradeability (tan θ) 0.57

Min. turning radius 11.0m

## CARRIER SPECIFICATIONS

### MANUFACTURER

MITSUBISHI MOTOR CORPORATION

### CARRIER MODEL

P-K450

### ENGINE

Model 8DC9

Type 4-cycle V8-cylinder, direct-injection, water-cooled diesel engine

Piston displacement 16,031cc

Max. output 320PS at 2,200rpm

Max. torque 110kg·m at 1,400rpm

### CLUTCH

Dry single-plate type

Hydraulic control with clutch booster

### TRANSMISSION

10-forward and 2-reverse speeds

Constant-mesh gear (1st speed, 2nd speed, reverse)

Synchronized-mesh gear (for 3rd – 10th speeds)

### REDUCER

1-stage speed reduction type

Hypoid gear type

### FRONT AXLE

Reverse-elliot type steering knuckles

### REAR AXLE

Full-floating type, cast-steel housing

### SUSPENSION

Front Laminated semi-elliptical leaf spring type  
With torsion bar stabilizer

(only for the front front axle)

Rear Equalizer beam and torque rod type

### STEERING

Recirculating ball screw type

With linkage type hydraulic power booster

### BRAKE SYSTEM

Service Brake

2-circuit air brakes for all wheels

Leading and trailing shoe type.

Parking Brake

Spring brake, acting on 4 rear wheels

Auxiliary Brake

Exhaust brake

### ELECTRIC SYSTEM

24 V DC. 2 batteries of 12V-145F51 (112Ah)

### FUEL TANK CAPACITY

300 liters

### CAB

Two-man type

### TIRES

Front 13.00-20-20PR

Rear 11.00-20-14PR

### STANDARD EQUIPMENTS

Car heater

Car radio

## GENERAL DATA

### DIMENSIONS

Overall length 12,860mm

Overall width 2,820mm

Overall height 3,750mm

Wheel base 1,450mm + 3,850mm + 1,350mm = 6,650mm

Tread Front 2,240mm

Rear 2,050mm

### WEIGHTS

Gross vehicle weight

Total 37,340kg

Front 16,335kg

Rear 21,005kg

### PERFORMANCE

Max. traveling speed 70km/h

Min. traveling speed 1.9km/h

Gradeability (tan  $\theta$ ) 0.31

Min. turning radius 11.0m

**TOTAL RATED LOADS**

(1) Standard specifications

(i)

**[BOOM]**

Unit : ton

· Outriggers fully extended + Front jack (360°) · Outriggers fully extended (Over rear · Over sides)					
A \ B (m)	10.65 m	18.0 m	25.3 m	32.7 m	40.0 m
3.0	45.00	28.00			
3.5	40.50	28.00			
4.0	36.50	28.00	20.00		
4.5	33.00	28.00	20.00		
5.0	30.20	28.00	20.00		
5.5	27.50	25.60	20.00	13.00	
6.0	25.00	23.50	20.00	13.00	
6.5	22.70	21.80	18.10	13.00	7.50
7.0	20.70	20.00	16.80	13.00	7.50
7.5	18.90	18.50	15.70	13.00	7.50
8.0	17.40	17.00	14.80	12.30	7.50
8.5	15.40	15.30	14.00	11.60	7.50
9.0	13.85	13.65	13.20	11.00	7.50
10.0		10.95	10.85	10.00	7.50
11.0		9.00	8.85	9.10	6.95
12.0		7.50	7.35	8.20	6.45
13.0		6.30	6.15	6.95	6.00
14.0		5.35	5.20	6.00	5.60
16.0		3.85	3.70	4.50	4.80
18.0			2.50	3.40	3.95
20.0			1.60	2.45	3.10
22.0			0.85	1.75	2.35
24.0				1.15	1.75
26.0				0.65	1.25
28.0					0.85
30.0					0.50

A = Boom length

B = Working radius

(1) Standard specifications  
 (ii)  
 [JIB]

Unit : ton

· Outriggers fully extended + Front jack (360°) · Outriggers fully extended (Over rear · Over sides)						
E (°)	9.0 m			16.0 m		
	5°	25°	45°	5°	25°	45°
80	3.50	2.20	1.20	2.30	1.10	0.60
79	3.50	2.20	1.20	2.30	1.10	0.60
78	3.50	2.20	1.20	2.30	1.10	0.60
77	3.32	2.14	1.19	2.18	1.07	0.59
76	3.13	2.08	1.18	2.06	1.05	0.59
75	2.97	2.02	1.17	1.96	1.02	0.58
73	2.68	1.91	1.15	1.78	0.97	0.57
70	2.33	1.74	1.11	1.56	0.91	0.56
68	2.15	1.64	1.09	1.44	0.87	0.54
65	1.91	1.49	1.07	1.27	0.81	0.53
63	1.78	1.39	1.03	1.18	0.78	0.51
60	1.45	1.25	1.00	1.06	0.74	0.50
58	1.16	1.03	0.98	0.93	0.68	0.49
55	0.82	0.69	0.66	0.63	0.47	
53	0.62					

C = Jib length  
 D = Jib offset  
 E = Boom angle

(1) Standard specifications  
 (iii)  
 [BOOM]

Unit : ton

· Outriggers middle extended (360°) · Outriggers fully extended (Over front)						Without outriggers (Over rear)	
A B (m)	10.65 m	18.0 m	25.3 m	32.7 m	40.0 m	A B (m)	10.65 m
3.0	40.00	28.00				3.0	8.00
3.5	34.00	28.00				3.5	6.40
4.0	28.60	28.00	20.00			4.0	5.10
4.5	26.20	26.05	20.00			4.5	4.20
5.0	19.60	19.50	19.40			5.0	3.40
5.5	15.40	15.25	15.20	13.00		5.5	2.80
6.0	12.60	12.30	12.25	13.00		6.0	2.30
6.5	10.40	10.15	10.10	11.30	7.50	6.5	1.90
7.0	8.70	8.50	8.45	9.60	7.50	7.0	1.60
7.5	7.40	7.20	7.20	8.20	7.50	7.5	1.25
8.0	6.30	6.25	6.15	7.10	7.50	8.0	1.00
8.5	5.40	5.40	5.30	6.15	6.90	A = Boom length B = Working radius	
9.0	4.65	4.65	4.55	5.40	6.10		
10.0		3.50	3.35	4.15	4.85		
11.0		2.50	2.45	3.30	3.85		
12.0		1.65	1.65	2.65	3.15		
13.0				1.95	2.50		
14.0				1.40	1.95		
16.0					1.15		

(1) Standard specifications

(iv)

[JIB]

Unit : ton

· Outriggers middle extended (360°) · Outriggers fully extended (Over front)							
E (°)	C	9.0 m			16.0 m		
	D	5°	25°	45°	5°	25°	45°
80		3.50	2.20	1.20	2.30	1.10	0.60
79		3.50	2.20	1.20	2.30	1.10	0.60
78		3.50	2.20	1.20	2.30	1.10	0.60
77		3.10	2.14	1.19	2.18	1.07	0.59
76		2.65	2.08	1.18	2.06	1.05	0.59
75		2.25	1.85	1.17	1.70	1.02	
73		1.55	1.30				

C = Jib length D = Jib offset E = Boom angle

**NOTES:**

1. The total rated loads shown are for the case when the outriggers are set horizontally on firm ground. The values are based on the crane strength.
2. The weights of slings and hooks (400kg for a 45 ton capacity hook, 200kg for a 12 ton capacity hook and 100kg for a 4 ton capacity hook) are included in the total rated loads shown.
3. The total rated load is based on the actual working radius including the deflection of the boom.
4. The chart below shows the standard number of part lines for each boom length. The load per line should not exceed 4.0t for both the main winch and the auxiliary winch.

A	10.65m	18.0 m	25.3 m	32.7 m	40.0 m	J
H	11	7	5	4	2	1

A = Boom length H = No. of part-line J = Jib / Single top

5. As a rule, free-fall operations should be performed only when lowering the hook alone. If a hoisted load must be lowered by free-fall operation, the load must be kept below 1/5th of the total rated load (the load per line must be 0.8t or less for both the main and the auxiliary winches) and sudden braking operations must be avoided. Free-fall operations should not be performed without the outriggers.
6. The total rated load for the single top is the same as that of the boom and must not exceed 4.0 tons. However, when hooks, slings, etc. are mounted on the boom, one should work with the total rated load obtained by subtracting the weights of the hooks, slings, etc. mounted on the boom from the total rated load of the boom.

(2) Specifications for the case  
when the device for heavy-duty work (option) is mounted

(i)

[BOOM]

Unit : ton

· Outriggers fully extended + Front jack (360°) · Outriggers fully extended (Over rear · Over sides)					
A \ B (m)	10.65 m	18.0 m	25.3 m	32.7 m	40.0 m
3.0	45.00	28.00			
3.5	40.50	28.00			
4.0	36.50	28.00	20.00		
4.5	33.00	28.00	20.00		
5.0	30.20	28.00	20.00		
5.5	27.50	25.60	20.00	13.00	
6.0	25.00	23.50	20.00	13.00	
6.5	22.70	21.80	18.10	13.00	7.50
7.0	20.70	20.00	16.80	13.00	7.50
7.5	18.90	18.50	15.70	13.00	7.50
8.0	17.40	17.00	14.80	12.30	7.50
8.5	16.05	15.70	14.00	11.60	7.50
9.0	14.90	14.70	13.20	11.00	7.50
10.0		12.20	11.80	10.00	7.50
11.0		10.15	10.00	9.10	6.95
12.0		8.50	8.35	8.30	6.45
13.0		7.30	7.15	7.65	6.00
14.0		6.25	6.10	6.95	5.60
16.0		4.60	4.50	5.35	4.80
18.0			3.35	4.15	4.05
20.0			2.35	3.20	3.55
22.0			1.60	2.45	3.00
24.0				1.80	2.35
26.0				1.30	1.80
28.0				0.85	1.35
30.0					1.00
32.0					0.70
34.0					0.40

A = Boom length

B = Working radius

(2) Specifications for the case  
 when the device for heavy-duty work (option) is mounted  
 (ii)  
 [JIB]

Unit : ton

· Outriggers fully extended + Front jack (360°) · Outriggers fully extended (Over rear · Over sides)						
E (°)	9.0 m			16.0 m		
	C	D	E	C	D	E
	5°	25°	45°	5°	25°	45°
80	3.50	2.20	1.20	2.30	1.10	0.60
79	3.50	2.20	1.20	2.30	1.10	0.60
78	3.50	2.20	1.20	2.30	1.10	0.60
77	3.32	2.14	1.19	2.18	1.07	0.59
76	3.13	2.08	1.18	2.06	1.05	0.59
75	2.97	2.02	1.17	1.96	1.02	0.58
73	2.68	1.91	1.15	1.78	0.97	0.57
70	2.33	1.74	1.11	1.56	0.91	0.56
68	2.15	1.64	1.09	1.44	0.87	0.54
65	1.91	1.49	1.07	1.27	0.81	0.53
63	1.78	1.39	1.03	1.18	0.78	0.51
60	1.60	1.26	1.00	1.06	0.74	0.50
58	1.46	1.19	0.98	0.98	0.72	0.49
55	1.15	1.02	0.94	0.90	0.70	0.47
53	0.94	0.80	0.76	0.72	0.56	0.46
50	0.66	0.52	0.48	0.45		

C = Jib length  
 D = Jib offset  
 E = Boom angle

(2) Specifications for the case  
when the device for heavy-duty work (option) is mounted  
(iii)  
[BOOM]

Unit : ton

· Outriggers middle extended (360°) · Outriggers fully extended (Over front)						Without outriggers (Over rear)	
A B (m)	10.65 m	18.0 m	25.3 m	32.7 m	40.0 m	A B (m)	10.65 m
3.0	40.00	28.00				3.0	8.00
3.5	35.00	28.00				3.5	6.40
4.0	30.00	28.00	20.00			4.0	5.10
4.5	26.60	26.50	20.00			4.5	4.20
5.0	23.45	23.35	20.00			5.0	3.40
5.5	18.55	18.40	18.35	13.00		5.5	2.80
6.0	15.10	15.00	14.95	13.00		6.0	2.30
6.5	12.60	12.50	12.40	13.00	7.50	6.5	1.90
7.0	10.65	10.55	10.50	11.65	7.50	7.0	1.60
7.5	9.10	9.00	8.95	10.05	7.50	7.5	1.25
8.0	7.85	7.80	7.70	8.75	7.50	8.0	1.00
8.5	6.85	6.75	6.70	7.70	7.50	A = Boom length B = Working radius	
9.0	6.00	5.90	5.80	6.80	6.90		
10.0		4.50	4.45	5.40	6.05		
11.0		3.45	3.35	4.30	4.95		
12.0		2.60	2.50	3.45	4.05		
13.0		1.95	1.75	2.75	3.35		
14.0		1.35	1.15	2.10	2.80		
16.0				1.15	1.75		
18.0					1.10		

(2) Specifications for the case  
 when the device for heavy-duty work (option) is mounted

(iv)  
 [JIB]

Unit : ton

· Outriggers middle extended (360°) · Outriggers fully extended (Over front)						
E (°)	9.0 m			16.0 m		
	5°	25°	45°	5°	25°	45°
80	3.50	2.20	1.20	2.30	1.10	0.60
79	3.50	2.20	1.20	2.30	1.10	0.60
78	3.50	2.20	1.20	2.30	1.10	0.60
77	3.32	2.14	1.19	2.18	1.07	0.59
76	3.13	2.08	1.18	2.06	1.05	0.59
75	2.95	2.02	1.17	1.96	1.02	0.58
73	2.20	1.80	1.15	1.78	0.97	
70	1.35					

C = Jib length D = Jib offset E = Boom angle

**NOTES:**

1. The total rated loads shown are for the case when the outriggers are set horizontally on firm ground. The values are based on the crane strength.
2. The weights of slings and hooks (400kg for a 45 ton capacity hook, 200kg for a 12 ton capacity hook and 100kg for a 4 ton capacity hook) are included in the total rated loads shown.
3. The total rated load is based on the actual working radius including the deflection of the boom.
4. The chart below shows the standard number of part lines for each boom length. The load per line should not exceed 4.0t for both the main winch and the auxiliary winch.

A	10.65m	18.0 m	25.3 m	32.7 m	40.0 m	J
H	11	7	5	4	2	1

A = Boom length H = No. of part-line J = Jib / Single top

5. As a rule, free-fall operations should be performed only when lowering the hook alone. If a hoisted load must be lowered by free-fall operation, the load must be kept below 1/5th of the total rated load (the load per line must be 0.8t or less for both the main and the auxiliary winches) and sudden braking operations must be avoided. Free-fall operations should not be performed without the outriggers.
6. The total rated load for the single top is the same as that of the boom and must not exceed 4.0 tons. However, when hooks, slings, etc. are mounted on the boom, one should work with the total rated load obtained by subtracting the weights of the hooks, slings, etc. mounted on the boom from the total rated load of the boom.

## WORKING RADIUS - LIFTING HEIGHT

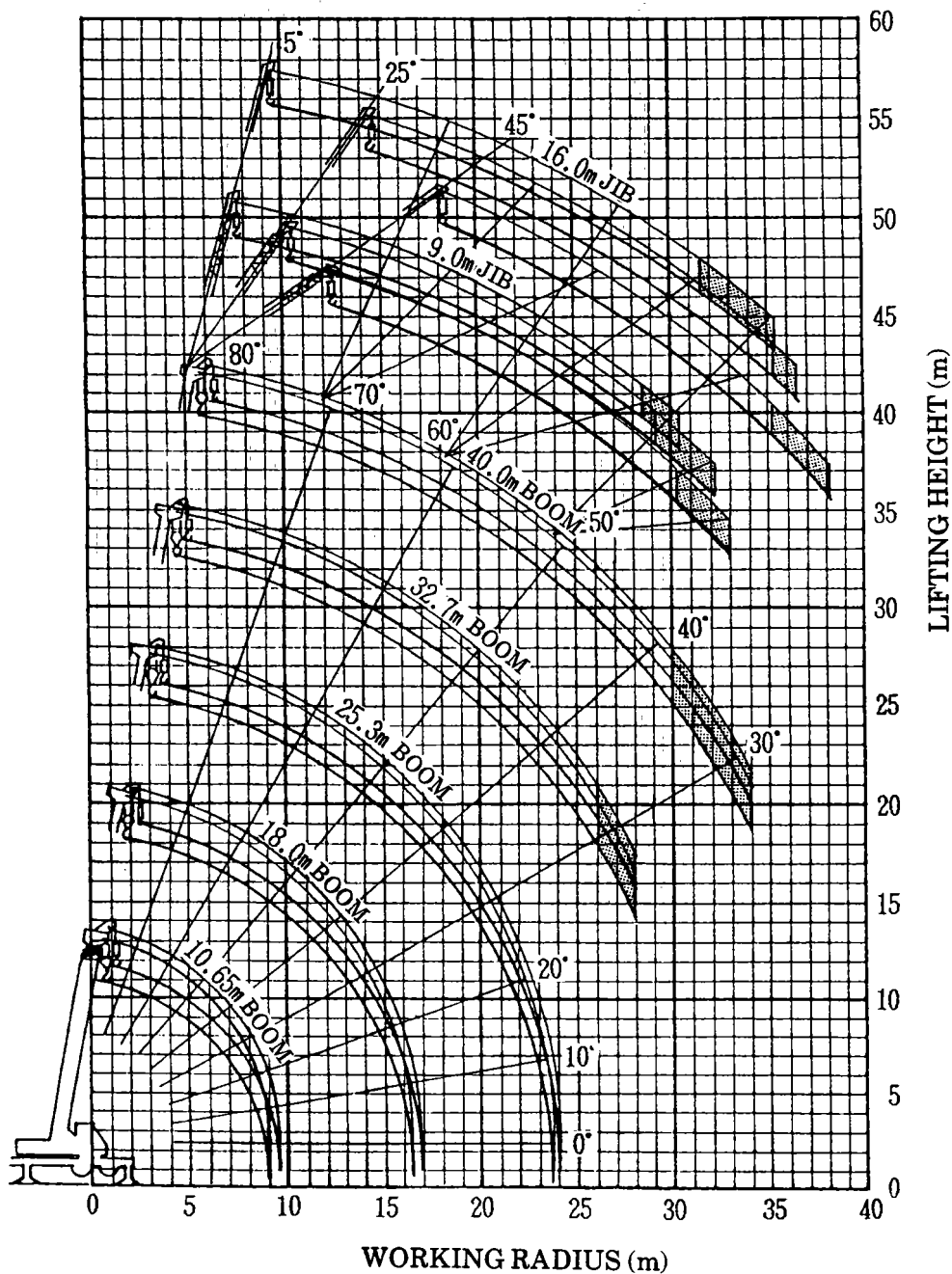

**NOTES:**

1. The deflection of the boom is not incorporated in the figure above.
2. The above chart is for the case where the outriggers are fully extended and where the front jack are used (over 360°)
3. The shaded area in the diagram applies only to the case when the device for heavy-duty work (option) is mounted.

**DIMENSIONS (1/100)**

K-KG54T

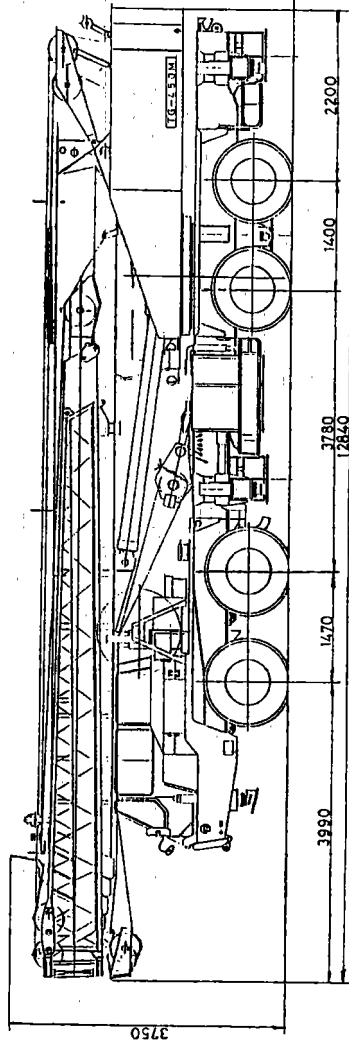
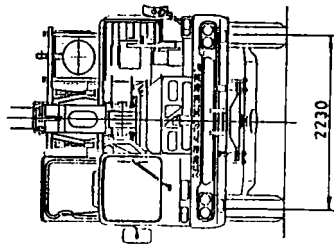
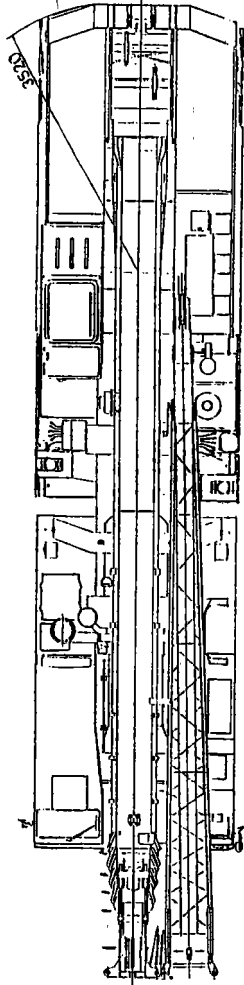
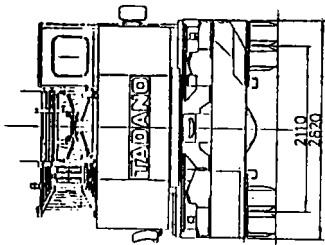

**DIMENSIONS (1/100)**

P-K450

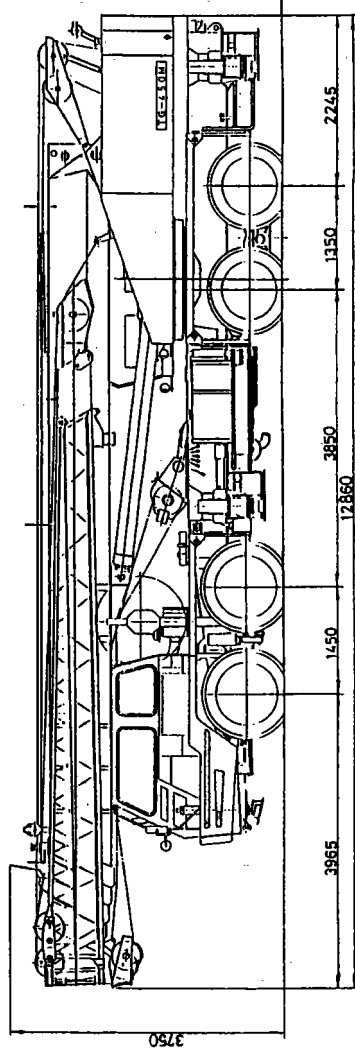
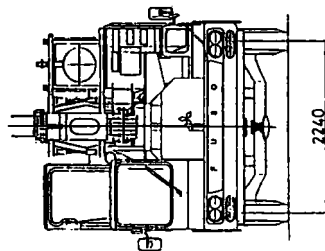
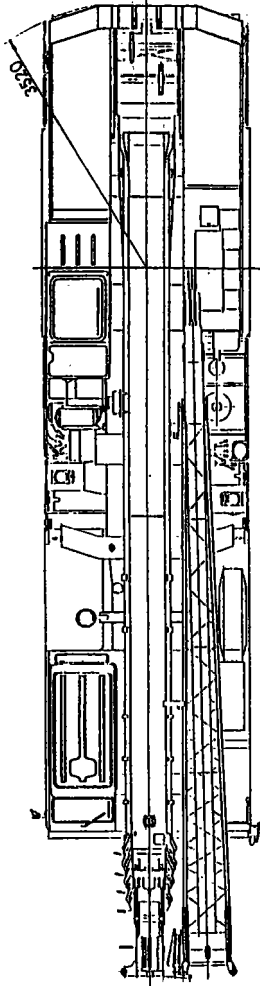
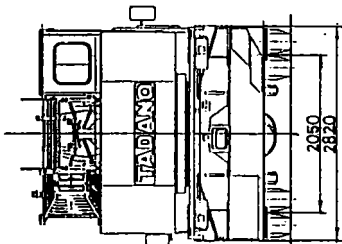

◆ MEMO ◆

A series of horizontal dashed lines for writing.