

ALL TERRAIN CRANE

AR-1200M

JAPANESE SPECIFICATIONS

CARRIER MODEL	SPEC. NO.
FAUN RTF120-5	AR-1200M-1

AR

Control No. JA-03

AR-1200M

CRANE SPECIFICATIONS

CRANE CAPACITY

12.2m Boom	120,000kg	at 2.7m	(17part-line)
21.0m Boom	50,000kg	at 7.0m	(7part-line)
29.8m Boom	34,000kg	at 8.0m	(5part-line)
38.7m Boom	24,000kg	at 10.0m	(4part-line)
47.5m Boom	13,000kg	at 16.0m	(4part-line)
9.8m Jib	7,000kg	at 73 °	(1part-line)
15.4m Jib	3,800kg	at 70 °	(1part-line)
21.0m Jib	2,500kg	at 68 °	(1part-line)

MAX.LIFTING HEIGHT

Boom	47.5m
Jib	68.0m

MAX.WORKING RADIUS

Boom	44.0m
Jib	53.7m

BOOM LENGTH

12.2m – 47.5m

BOOM EXTENSION

35.3m

BOOM EXTENSION SPEED

35.3m/110s

JIB LENGTH

9.8m – 21.0m

MAIN WINCH SINGLE LINE SPEED

135m/min (4th layer)

MAIN WINCH HOOK SPEED

7.9m/min (17 part-line)

AUXILIARY WINCH SINGLE LINE SPEED

135m/min (4th layer)

AUXILIARY WINCH HOOK SPEED

135m/min (1 part-line)

BOOM ELEVATION ANGLE

-2 °~ 81.5 °

BOOM ELEVATION SPEED

-2 °~ 81.5 °/55s

SWING ANGLE

360 °continue

SWING SPEED

1.5rpm

WIRE ROPE

Main Winch

22mm x 255m (Diameter x Length)
Anti-rotate wire rope

Auxiliary Winch

22mm x 145m (Diameter x Length)
Anti-rotate wire rope

HOOK

120t hook	(17part-line)
50t hook	(7part-line)
8t hook	(1part-line)

BOOM

5-section hydraulically telescoping boom of box construction

Two telescoping methods selection type

Telescoping method I

(stages 2,3: synchronized; stages 4,5: synchronized)

Telescoping method II

(stages 2 – 5: synchronized)

BOOM EXTENSION

3 double-acting hydraulic cylinders

1 wire rope type telescoping device

With flow regulator valve with pressure compensation

JIB

Folding type which stores alongside the boom

3-section hydraulically synchronously telescoping boom

Hydraulic non-stage offset (5 °~ 45 °) type

SINGLE TOP

Single sheave. Mounted to main boom head for single line work.

HOIST

Driven by hydraulic variable motor and via planetary gear reducer.

Automatic brake

2 single winches

With flow regulator valve with pressure compensation

BOOM ELEVATION

1 double-acting hydraulic cylinder

With flow regulator valve with pressure compensation

SWING

Hydraulic motor driven planetary gear reducer

Swing bearing

Manual switch brake

2-speed (high/low) selection type

OUTRIGGERS

Fully hydraulic H-type

Slides and jacks each provided with independent operation device.

Fully extended width 8.0m

Middle extended width 7.0m, 5.3m, 4.6m

Extended width detector provided.

Slide storing float

MAX. VERTICAL LOAD CAPACITY OF OUTRIGGER

83t

ENGINE FOR CRANE

Engine exclusive to upper component operation

Model NISSAN DIESEL NE6T

Type 4-cycle, 6 in-line cylinder, direct-injection, water-cooled diesel engine

Piston displacement 7,412cc with turbo charger

Max. output 180PS at 2,200rpm

Max. torque 69.0kg-m at 1,500rpm

FUEL TANK CAPACITY

250 liters

HYDRAULIC PUMPS

2 variable piston pumps and 2 variable gear pumps

HYDRAULIC OIL TANK CAPACITY

1,000 liters

SAFETY DEVICES

Automatic moment limiter (AML)

Multiple display

With working range limiting function

Outrigger extension automatic detector (individual detection)

Weight combination automatic detector

Swing range controller

Swing automatic stop device

Boom elevation slow down and stop device

Over-winding cutout device

Dead winding holding device

Cable follower

Hook safety latch

Winch drum lock

Hydraulic safety valve

Hydraulic lock (elevation, telescoping, hoist, jack, jib tilt, counterweight)

Swing lock

Boom angle indicator

Level gauge

EQUIPMENT

Counterweight dismount device

Jib extension device

Oil cooler

Boom dismount device

Swing frame dismount device

AML external indication lamp

Hook movement amount indicator

Iron plate

Air conditioner

FM radio

Hot and cool boxes

Lunch table

OPTIONAL EQUIPMENT

Swing alarm

Drum monitor

CARRIER SPECIFICATIONS

MANUFACTURER

FAUN GmbH

CARRIER MODEL

RTF 120-5

ENGINE

Model OM442LA (Benz)

Type 4-cycle, V8-cylinder, direct-injection, turbo diesel engine with inter cooler

Piston displacement 14,618cc

Max. output 503PS at 2,100rpm

Max. torque 206kg·m at 1,100 to 1,600rpm

TRANSMISSION

Fully automatic

5-forward and 1-reverse speeds

Sub-transmission provided.

CLUTCH

Torque converter provided.

Automatic lock-up mechanism provided.

DRIVING METHOD

10 x 6

10 x 8 · · · Off load (with def-lock mechanism)

AXLE (all axles)

Full-floating type

SUSPENSION (all axles)

Hydraulic pneumatic suspension

Stroke: +149mm/-113mm

STEERING

Type: Left-side handle

Fully hydraulic power steering

2 circuits

Emergency power steering

Mode: Normal (6 front wheels)

Clamp (10 wheels)

Crab (10 wheels)

Rear steering (4 rear wheels)

BRAKE SYSTEM

Service Brake

Air brake on all wheels

2 circuits

Parking Brake

4th and 5th axles (4-wheel) spring brake for public thoroughfare traveling

(3rd, 4th and 5th axles (6-wheel) spring brake for on-site traveling)

Emergency Brake

Works by applying the parking brake

Auxiliary Brake

Flow type retarder (transmission built-in)

Exhaust brake

ELECTRIC SYSTEM

24 V DC. 2 batteries of 12V-170Ah

FUEL TANK CAPACITY

570 liters

CAB

Two-man type

TIRES

16.00R25 (all wheels)

WHEEL

11.25-25 (all wheels)

STANDARD EQUIPMENT

Car air conditioner

FM radio

Mud guard

Centralized lubrication unit

Bed for napping

OPTIONAL EQUIPMENT

Back monitor

GENERAL DATA

DIMENSIONS (CARRIER ONLY)

Overall length 12,140mm

Overall width 3,000mm

Overall height 2,755mm

Wheel base 2,600mm + 1,700mm + 1,750mm + 1,650mm

Tread 2,557mm

WEIGHTS (CARRIER ONLY)

Gross vehicle weight

Total 34,180kg (Two-man type)

Front: 1st + 2nd axle 17,280kg

Rear: 3rd axle 1,400kg

4th + 5th axle 15,500kg

PERFORMANCE (CARRIER ONLY)

Max. traveling speed 70km/h

Gradeability (tan) 0.70

Min. turning radius

6-wheel steering 11.9m

10-wheel steering 8.5m

TOTAL RATED LOADS

1. The total rated loads shown are for the case where the outriggers are set horizontally on firm level ground. The values above the bold lines are based on the crane strength while those below are based on the crane stability.
2. The weights of the slings and hooks (120t hook: 1,300kg , 50t hook: 600kg, 8t hook: 250kg) are included in the total rated loads shown.
The boom-side attachment (100kg) is included.
3. The total rated load is based on the actual working radius including the deflection of the boom.
4. The table below shows the classification of Performances A to G of the total rated load.

Counterweight Outrigger extension width	22t	12t
8.0m	A	B
7.0m	C	D
5.3m	E	F
4.6m	F*	G*

Mark* Shows the performance of the boom.

5. The chart below shows the standard number of part lines for each boom length. The load per line should not exceed 7.5t for the main winch and 8.0t for the auxiliary winch.

A	12.2m	21.0m	29.8m	38.7m	47.5m	J
H	(17)13	7	5	4	4	1

A= Boom length H= No. of part-lines J= Jib/Single top

The value in parenthesis is for the case where an attachment is used.

6. The total rated load for the single top shall be the value obtained by subtracting the weight of the hook mounted to the boom from the total rated load of the boom and must not exceed 8.0t.
7. Jib operation should be performed on the basis of the boom angle. The working radii are reference values for the case where a jib is mounted to a 47.5m boom.
8. The jib should be operated with the boom "telescoping method I".
9. When the maximum instantaneous velocity is 10m/s or more, stop crane operation.

[BOOM]

Unit: ton

Performance A								
A \ B	12.2m	21.0m		29.8m		38.7m		47.5m
2.7m	120.0	50.0	21.0					
3.0m	110.0	50.0	21.0					
3.5m	98.0	50.0	21.0	34.0	21.0			
4.0m	91.0	50.0	21.0	34.0	21.0			
4.5m	84.0	50.0	21.0	34.0	21.0			
5.0m	77.0	50.0	21.0	34.0	21.0	24.0	21.0	
5.5m	69.0	50.0	21.0	34.0	21.0	24.0	21.0	
6.0m	63.0	50.0	21.0	34.0	21.0	24.0	21.0	13.0
6.5m	58.0	50.0	21.0	34.0	21.0	24.0	21.0	13.0
7.0m	53.0	50.0	21.0	34.0	21.0	24.0	21.0	13.0
8.0m	45.5	46.0	21.0	34.0	21.0	24.0	21.0	13.0
9.0m	39.5	40.0	21.0	31.2	21.0	24.0	21.0	13.0
10.0m		35.2	21.0	28.4	21.0	24.0	21.0	13.0
11.0m		31.2	21.0	25.9	21.0	22.6	20.7	13.0
12.0m		28.0	21.0	23.8	21.0	20.8	19.2	13.0
14.0m		21.7	21.0	20.3	21.0	18.0	16.7	13.0
16.0m		17.2	18.6	17.2	19.0	15.6	14.8	13.0
18.0m		13.9	15.2	13.9	15.7	13.7	13.2	12.0
20.0m				11.3	13.1	12.1	11.8	10.8
22.0m				9.3	11.1	10.6	10.7	9.7
24.0m				7.6	9.5	9.0	9.7	8.8
26.0m				6.1	8.1	7.6	8.4	8.0
28.0m						6.4	7.2	7.2
30.0m						5.3	6.2	6.4
32.0m						4.4	5.3	5.5
34.0m						3.6	4.5	4.7
36.0m						2.9	3.8	4.0
38.0m								3.4
40.0m								2.8
42.0m								2.3
44.0m								1.9
(°)	0 ~ 81.5	0 ~ 81.5	0 ~ 81.5	0 ~ 81.5	0 ~ 81.5	0 ~ 81.5	0 ~ 81.5	10 ~ 81.5
Boom stage telescoping condition (%)								
Telescoping method	I, II	I	II	I	II	I	II	I, II
2nd boom	0	50	25	100	50	100	75	100
3rd boom	0	50	25	100	50	100	75	100
4th boom	0	0	25	0	50	50	75	100
5th boom	0	0	25	0	50	50	75	100

A= Boom length B= Working radius
= Boom angle range (for the unladen condition)

[BOOM]

Unit : ton

Performance B								
B \ A	12.2m	21.0m		29.8m		38.7m		47.5m
2.7m	100.0	50.0	21.0					
3.0m	97.0	50.0	21.0					
3.5m	88.0	50.0	21.0	34.0	21.0			
4.0m	80.0	50.0	21.0	34.0	21.0			
4.5m	73.0	50.0	21.0	34.0	21.0			
5.0m	67.5	50.0	21.0	34.0	21.0	24.0	21.0	
5.5m	62.5	50.0	21.0	34.0	21.0	24.0	21.0	
6.0m	58.0	50.0	21.0	34.0	21.0	24.0	21.0	13.0
6.5m	53.0	50.0	21.0	34.0	21.0	24.0	21.0	13.0
7.0m	49.0	49.5	21.0	34.0	21.0	24.0	21.0	13.0
8.0m	42.0	42.4	21.0	34.0	21.0	24.0	21.0	13.0
9.0m	36.5	36.8	21.0	31.2	21.0	24.0	21.0	13.0
10.0m		31.5	21.0	28.4	21.0	24.0	21.0	13.0
11.0m		26.6	21.0	25.9	21.0	22.6	20.7	13.0
12.0m		22.8	21.0	22.8	21.0	20.8	19.2	13.0
14.0m		17.3	18.6	17.2	19.2	18.0	16.7	13.0
16.0m		13.4	14.7	13.4	15.3	14.9	14.8	13.0
18.0m		10.6	11.9	10.6	12.5	12.0	12.7	12.0
20.0m				8.5	10.3	9.8	10.5	10.7
22.0m				6.6	8.5	8.1	8.8	8.9
24.0m				5.1	7.2	6.7	7.4	7.5
26.0m				3.8	6.0	5.4	6.2	6.4
28.0m						4.3	5.1	5.3
30.0m						3.4	4.2	4.4
32.0m						2.6	3.4	3.6
34.0m						1.9	2.8	2.9
36.0m						1.3	2.2	2.3
38.0m								1.8
40.0m								1.3
(°)	0 ~ 81.5	0 ~ 81.5	0 ~ 81.5	0 ~ 81.5	0 ~ 81.5	0 ~ 81.5	0 ~ 81.5	23 ~ 81.5
Boom stage telescoping condition (%)								
Telescoping method	I, II	I	II	I	II	I	II	I, II
2nd boom	0	50	25	100	50	100	75	100
3rd boom	0	50	25	100	50	100	75	100
4th boom	0	0	25	0	50	50	75	100
5th boom	0	0	25	0	50	50	75	100

A= Boom length B= Working radius
= Boom angle range (for the unladen condition)

[BOOM]

Unit: ton

Performance C								
A \ B	12.2m	21.0m		29.8m		38.7m		47.5m
2.7m	97.0	50.0	21.0					
3.0m	91.0	50.0	21.0					
3.5m	83.0	50.0	21.0	34.0	21.0			
4.0m	76.0	50.0	21.0	34.0	21.0			
4.5m	70.0	50.0	21.0	34.0	21.0			
5.0m	64.0	50.0	21.0	34.0	21.0	24.0	21.0	
5.5m	59.0	50.0	21.0	34.0	21.0	24.0	21.0	
6.0m	55.2	50.0	21.0	34.0	21.0	24.0	21.0	13.0
6.5m	51.5	50.0	21.0	34.0	21.0	24.0	21.0	13.0
7.0m	48.5	48.8	21.0	34.0	21.0	24.0	21.0	13.0
8.0m	42.7	43.0	21.0	34.0	21.0	24.0	21.0	13.0
9.0m	37.9	38.2	21.0	31.2	21.0	24.0	21.0	13.0
10.0m		34.2	21.0	28.4	21.0	24.0	21.0	13.0
11.0m		30.8	21.0	25.9	21.0	22.6	20.7	13.0
12.0m		27.6	21.0	23.8	21.0	20.8	19.2	13.0
14.0m		20.9	21.0	20.3	21.0	18.0	16.7	13.0
16.0m		16.3	17.7	16.3	18.3	15.6	14.8	13.0
18.0m		13.0	14.4	13.0	14.9	13.7	13.2	12.0
20.0m				10.5	12.4	11.9	11.8	10.8
22.0m				8.5	10.4	9.9	10.6	9.7
24.0m				6.8	8.8	8.3	9.0	8.8
26.0m				5.4	7.5	7.0	7.7	7.7
28.0m						5.8	6.5	6.6
30.0m						4.7	5.6	5.6
32.0m						3.8	4.7	4.7
34.0m						3.1	3.9	3.9
36.0m						2.5	3.3	3.3
38.0m								2.7
40.0m								2.1
42.0m								1.7
43.9m								1.3
(°)	0 ~ 81.5	0 ~ 81.5	0 ~ 81.5	0 ~ 81.5	0 ~ 81.5	0 ~ 81.5	0 ~ 81.5	12 ~ 81.5
Boom stage telescoping condition (%)								
Telescoping method	I, II	I	II	I	II	I	II	I, II
2nd boom	0	50	25	100	50	100	75	100
3rd boom	0	50	25	100	50	100	75	100
4th boom	0	0	25	0	50	50	75	100
5th boom	0	0	25	0	50	50	75	100

A= Boom length B= Working radius
= Boom angle range (for the unladen condition)

[BOOM]

Unit : ton

Performance D								
B \ A	12.2m	21.0m		29.8m		38.7m		47.5m
2.7m	95.0	50.0	21.0					
3.0m	89.0	50.0	21.0					
3.5m	81.0	50.0	21.0	34.0	21.0			
4.0m	74.0	50.0	21.0	34.0	21.0			
4.5m	68.0	50.0	21.0	34.0	21.0			
5.0m	62.0	50.0	21.0	34.0	21.0	24.0	21.0	
5.5m	58.0	50.0	21.0	34.0	21.0	24.0	21.0	
6.0m	53.8	50.0	21.0	34.0	21.0	24.0	21.0	13.0
6.5m	50.0	50.0	21.0	34.0	21.0	24.0	21.0	13.0
7.0m	46.8	47.1	21.0	34.0	21.0	24.0	21.0	13.0
8.0m	41.1	41.4	21.0	34.0	21.0	24.0	21.0	13.0
9.0m	36.4	36.7	21.0	31.2	21.0	24.0	21.0	13.0
10.0m		30.1	21.0	28.4	21.0	24.0	21.0	13.0
11.0m		25.0	21.0	24.9	21.0	22.6	20.7	13.0
12.0m		21.2	21.0	21.1	21.0	20.8	19.2	13.0
14.0m		15.7	17.2	15.7	17.8	17.1	16.7	13.0
16.0m		12.0	13.4	11.9	13.9	13.4	14.2	13.0
18.0m		9.1	10.6	9.2	11.2	10.7	11.4	11.4
20.0m				7.1	9.1	8.6	9.3	9.3
22.0m				5.3	7.4	6.9	7.6	7.7
24.0m				3.9	6.1	5.5	6.3	6.4
26.0m				2.7	4.9	4.3	5.2	5.2
28.0m						3.3	4.1	4.2
30.0m						2.4	3.3	3.3
32.0m						1.7	2.6	2.6
34.0m						1.1	1.9	2.0
36.0m							1.3	1.4
(°)	0 ~ 81.5	0 ~ 81.5	0 ~ 81.5	0 ~ 81.5	0 ~ 81.5	12 ~ 81.5	0 ~ 81.5	34 ~ 81.5
Boom stage telescoping condition (%)								
Telescoping method	I, II	I	II	I	II	I	II	I, II
2nd boom	0	50	25	100	50	100	75	100
3rd boom	0	50	25	100	50	100	75	100
4th boom	0	0	25	0	50	50	75	100
5th boom	0	0	25	0	50	50	75	100

A= Boom length B= Working radius
= Boom angle range (for the unladen condition)

[BOOM]

Unit: ton

Performance E								
A \ B	12.2m	21.0m		29.8m		38.7m		47.5m
2.7m	83.0	50.0	21.0					
3.0m	78.0	50.0	21.0					
3.5m	71.0	50.0	21.0	34.0	21.0			
4.0m	65.0	50.0	21.0	34.0	21.0			
4.5m	60.0	50.0	21.0	34.0	21.0			
5.0m	55.0	50.0	21.0	34.0	21.0	24.0	21.0	
5.5m	51.0	50.0	21.0	34.0	21.0	24.0	21.0	
6.0m	47.5	48.0	21.0	34.0	21.0	24.0	21.0	13.0
6.5m	44.5	44.8	21.0	34.0	21.0	24.0	21.0	13.0
7.0m	41.6	41.8	21.0	34.0	21.0	24.0	21.0	13.0
8.0m	36.5	36.8	21.0	34.0	21.0	24.0	21.0	13.0
9.0m	31.2	31.5	21.0	31.2	21.0	24.0	21.0	13.0
10.0m		26.2	21.0	26.0	21.0	24.0	21.0	13.0
11.0m		22.1	21.0	22.0	21.0	22.6	20.7	13.0
12.0m		18.9	20.4	18.9	20.9	20.2	19.2	13.0
14.0m		14.2	15.6	14.2	16.2	15.6	16.3	13.0
16.0m		11.0	12.3	10.9	12.8	12.3	13.0	13.0
18.0m		8.6	9.9	8.5	10.3	9.9	10.6	10.5
20.0m				6.5	8.4	8.0	8.7	8.7
22.0m				4.8	6.9	6.4	7.1	7.2
24.0m				3.5	5.7	5.1	5.9	6.0
26.0m				2.4	4.5	3.9	4.8	4.8
28.0m						3.0	3.8	3.9
30.0m						2.2	3.0	3.1
32.0m						1.5	2.3	2.4
34.0m							1.7	1.7
36.0m							1.1	1.2
(°)	0 ~ 81.5	0 ~ 81.5	0 ~ 81.5	0 ~ 81.5	0 ~ 81.5	22 ~ 81.5	0 ~ 81.5	34 ~ 81.5
Boom stage telescoping condition (%)								
Telescoping method	I, II	I	II	I	II	I	II	I, II
2nd boom	0	50	25	100	50	100	75	100
3rd boom	0	50	25	100	50	100	75	100
4th boom	0	0	25	0	50	50	75	100
5th boom	0	0	25	0	50	50	75	100

A= Boom length B= Working radius
= Boom angle range (for the unladen condition)

[BOOM]

Unit : ton

Performance F								
B \ A	12.2m	21.0m		29.8m		38.7m		47.5m
2.7m	73.0	50.0	21.0					
3.0m	70.0	50.0	21.0					
3.5m	67.0	50.0	21.0	34.0	21.0			
4.0m	61.0	50.0	21.0	34.0	21.0			
4.5m	56.0	50.0	21.0	34.0	21.0			
5.0m	51.5	50.0	21.0	34.0	21.0	24.0	21.0	
5.5m	47.7	48.0	21.0	34.0	21.0	24.0	21.0	
6.0m	44.3	44.6	21.0	34.0	21.0	24.0	21.0	13.0
6.5m	41.3	41.6	21.0	34.0	21.0	24.0	21.0	13.0
7.0m	37.9	38.4	21.0	34.0	21.0	24.0	21.0	13.0
8.0m	29.3	29.7	21.0	29.7	21.0	24.0	21.0	13.0
9.0m	23.4	23.8	21.0	23.8	21.0	24.0	21.0	13.0
10.0m		19.5	21.0	19.5	21.0	21.1	21.0	13.0
11.0m		16.2	17.7	16.2	18.3	17.8	18.6	13.0
12.0m		13.6	15.1	13.6	15.7	15.2	16.0	13.0
14.0m		9.9	11.2	9.9	11.8	11.3	12.0	12.1
16.0m		7.3	8.6	7.3	9.0	8.6	9.3	9.4
18.0m		5.1	6.7	5.1	7.1	6.7	7.4	7.4
20.0m				3.4	5.6	5.0	5.9	5.9
22.0m				2.1	4.3	3.7	4.5	4.6
24.0m				1.0	3.2	2.6	3.4	3.5
26.0m					2.3	1.7	2.5	2.6
28.0m							1.7	1.8
(°)	0 ~ 81.5	0 ~ 81.5	0 ~ 81.5	22 ~ 81.5	0 ~ 81.5	41 ~ 81.5	36 ~ 81.5	50 ~ 81.5
Boom stage telescoping condition (%)								
Telescoping method	I, II	I	II	I	II	I	II	I, II
2nd boom	0	50	25	100	50	100	75	100
3rd boom	0	50	25	100	50	100	75	100
4th boom	0	0	25	0	50	50	75	100
5th boom	0	0	25	0	50	50	75	100

A= Boom length B= Working radius
= Boom angle range (for the unladen condition)

[BOOM]

Unit: ton

Performance G								
A \ B	12.2m	21.0m		29.8m		38.7m		47.5m
2.7m	71.0	50.0	21.0					
3.0m	68.0	50.0	21.0					
3.5m	64.5	50.0	21.0	34.0	21.0			
4.0m	59.0	50.0	21.0	34.0	21.0			
4.5m	54.0	50.0	21.0	34.0	21.0			
5.0m	49.5	50.0	21.0	34.0	21.0	24.0	21.0	
5.5m	45.8	46.3	21.0	34.0	21.0	24.0	21.0	
6.0m	39.9	40.2	21.0	34.0	21.0	24.0	21.0	13.0
6.5m	34.6	34.6	21.0	34.0	21.0	24.0	21.0	13.0
7.0m	29.7	30.1	21.0	29.8	21.0	24.0	21.0	13.0
8.0m	23.1	23.5	21.0	23.3	21.0	24.0	21.0	13.0
9.0m	18.4	18.7	20.5	18.7	20.9	20.2	21.0	13.0
10.0m		15.4	16.9	15.3	17.5	16.8	17.6	13.0
11.0m		12.7	14.1	12.7	14.7	14.1	14.9	13.0
12.0m		10.6	12.0	10.6	12.5	12.0	12.8	12.7
14.0m		7.5	8.8	7.5	9.3	8.9	9.5	9.6
16.0m		5.0	6.5	5.0	7.0	6.6	7.2	7.3
18.0m		3.1	4.7	3.1	5.3	4.7	5.5	5.6
20.0m					3.8	3.2	4.1	4.2
22.0m					2.6		2.9	3.0
(°)	0 ~ 81.5	0 ~ 81.5	0 ~ 81.5	44 ~ 81.5	31 ~ 81.5	50 ~ 81.5	46 ~ 81.5	56 ~ 81.5
Boom stage telescoping condition (%)								
Telescoping method	I, II	I	II	I	II	I	II	I, II
2nd boom	0	50	25	100	50	100	75	100
3rd boom	0	50	25	100	50	100	75	100
4th boom	0	0	25	0	50	50	75	100
5th boom	0	0	25	0	50	50	75	100

A= Boom length B= Working radius
= Boom angle range (for the unladen condition)

[JIB]

Performance A

Unit: ton

C D	47.5m Boom + 9.8m Jib						47.5m Boom + 15.4m Jib					
	5 °		25 °		45 °		5 °		25 °		45 °	
E (°)	B (m)	M	B (m)	M	B (m)	M	B (m)	M	B (m)	M	B (m)	M
81.5	8.2	7.00	11.3	6.50	13.2	3.90	9.3	3.80	14.2	3.10	17.6	1.95
80	10.5	7.00	13.5	6.50	15.2	3.90	11.7	3.80	16.5	3.10	19.8	1.95
78	12.7	7.00	15.7	6.50	17.2	3.90	14.2	3.80	18.8	3.10	21.9	1.95
75	16.1	7.00	18.8	6.20	20.1	3.75	17.8	3.80	22.1	2.90	24.9	1.85
73	18.2	7.00	20.7	5.80	22.0	3.65	20.1	3.80	24.2	2.80	26.9	1.80
70	21.3	6.50	23.6	5.25	24.8	3.50	23.6	3.80	27.4	2.65	29.7	1.74
68	23.2	6.00	25.4	4.90	26.6	3.45	25.8	3.70	29.4	2.55	31.6	1.70
65	26.0	5.20	28.1	4.45	29.2	3.35	28.9	3.40	32.3	2.45	34.3	1.64
63	27.8	4.80	29.9	4.20	30.9	3.30	30.9	3.25	34.3	2.40	36.0	1.61
60	30.3	4.15	32.3	3.70	33.3	3.20	33.9	3.05	37.0	2.35	38.5	1.57
58	32.0	3.80	33.9	3.40	34.8	3.15	35.8	2.95	38.8	2.30	40.1	1.55
55	34.4	3.30	36.2	3.00	37.0	2.85	38.5	2.70	41.3	2.20	42.3	1.53
53	35.9	3.00	37.6	2.70	38.3	2.60	40.2	2.45	42.9	2.15	43.8	1.50
50	38.1	2.35	39.6	2.15	40.2	2.05	42.5	1.95	45.0	1.70	45.8	1.45
48	39.4	1.90	40.9	1.75	41.4	1.65	44.0	1.60	46.3	1.40	47.0	1.25
45	41.4	1.35	42.7	1.25			46.0	1.10	48.2	0.95		
(°)	44 ~ 81.5		44 ~ 81.5		47 ~ 81.5		44 ~ 81.5		44 ~ 81.5		47 ~ 81.5	

Unit: ton

C D	47.5m Boom + 21.0m Jib					
	5 °		25 °		45 °	
E (°)	B (m)	M	B (m)	M	B (m)	M
81.5	10.6	2.50	17.4	1.85	22.2	1.00
80	13.2	2.50	19.9	1.85	24.4	1.00
78	15.9	2.50	22.4	1.85	26.6	1.00
75	19.8	2.50	25.9	1.75	29.8	1.00
73	22.4	2.50	28.2	1.65	31.9	1.00
70	26.2	2.50	31.5	1.55	34.9	1.00
68	28.6	2.50	33.6	1.50	36.8	0.98
65	32.0	2.25	36.8	1.45	39.6	0.94
63	34.2	2.10	38.8	1.40	41.4	0.92
60	37.4	1.95	41.7	1.35	43.9	0.90
58	39.4	1.85	43.6	1.30	45.5	0.89
55	42.4	1.70	46.2	1.26	47.8	0.87
53	44.2	1.60	47.9	1.23	49.3	0.86
50	47.0	1.50	50.3	1.20	51.3	0.85
48	48.6	1.30	51.8	1.10	52.5	0.84
45	50.8	0.85	53.7	0.80		
(°)	44 ~ 81.5		44 ~ 81.5		47 ~ 81.5	

B= Working radius C= Jib length D= Jib offset

E= Boom angle M= Total rated loads

= Boom angle range (for the unladen condition)

[JIB]

Performance B

Unit: ton

C	47.5m Boom + 9.8m Jib						47.5m Boom + 15.4m Jib					
	5 °		25 °		45 °		5 °		25 °		45 °	
D	B (m)	M	B (m)	M	B (m)	M	B (m)	M	B (m)	M	B (m)	M
E (°)												
81.5	8.2	7.00	11.3	6.50	13.2	3.90	9.3	3.80	14.2	3.10	17.6	1.95
80	10.5	7.00	13.5	6.50	15.2	3.90	11.7	3.80	16.5	3.10	19.8	1.95
78	12.7	7.00	15.7	6.50	17.2	3.90	14.2	3.80	18.8	3.10	21.9	1.95
75	16.1	7.00	18.8	6.20	20.1	3.75	17.8	3.80	22.1	2.90	24.9	1.85
73	18.2	7.00	20.7	5.80	22.0	3.65	20.1	3.80	24.2	2.80	26.9	1.80
70	21.3	6.50	23.6	5.25	24.8	3.50	23.6	3.80	27.4	2.65	29.7	1.74
68	23.2	6.00	25.4	4.90	26.6	3.45	25.8	3.70	29.4	2.55	31.6	1.70
65	26.0	5.20	28.1	4.45	29.2	3.35	28.9	3.40	32.3	2.45	34.3	1.64
63	27.7	4.65	29.9	4.15	30.9	3.30	30.9	3.25	34.3	2.40	36.0	1.61
60	30.1	3.40	32.1	3.05	33.2	2.85	33.8	2.85	37.0	2.35	38.5	1.57
58	31.6	2.70	33.6	2.40	34.6	2.25	35.5	2.25	38.6	1.85	40.1	1.55
55	33.9	1.80	35.7	1.60	36.6	1.45	37.9	1.45	40.8	1.20	42.2	1.00
53	35.3	1.30	37.0	1.10	37.8	1.00	39.4	1.00				
(°)	52 ~ 81.5		52 ~ 81.5		52 ~ 81.5		52 ~ 81.5		54 ~ 81.5		54 ~ 81.5	

Unit: ton

C	47.5m Boom + 21.0m Jib					
	5 °		25 °		45 °	
D	B (m)	M	B (m)	M	B (m)	M
E (°)						
81.5	10.6	2.50	17.4	1.85	22.2	1.00
80	13.2	2.50	19.9	1.85	24.4	1.00
78	15.9	2.50	22.4	1.85	26.6	1.00
75	19.8	2.50	25.9	1.75	29.8	1.00
73	22.4	2.50	28.2	1.65	31.9	1.00
70	26.2	2.50	31.5	1.55	34.9	1.00
68	28.6	2.50	33.6	1.50	36.8	0.98
65	32.0	2.25	36.8	1.45	39.6	0.94
63	34.2	2.10	38.8	1.40	41.4	0.92
60	37.4	1.95	41.7	1.35	43.9	0.90
58	39.4	1.85	43.6	1.30	45.5	0.89
55	42.0	1.15	46.0	0.90		
53						
(°)	54 ~ 81.5		54 ~ 81.5		57 ~ 81.5	

B= Working radius C= Jib length D= Jib offset

E= Boom angle M= Total rated loads

= Boom angle range (for the unladen condition)

[JIB]

Performance C

Unit: ton

C D	47.5m Boom + 9.8m Jib						47.5m Boom + 15.4m Jib					
	5 °		25 °		45 °		5 °		25 °		45 °	
E (°)	B (m)	M	B (m)	M	B (m)	M	B (m)	M	B (m)	M	B (m)	M
81.5	8.2	7.00	11.3	6.50	13.2	3.90	9.3	3.80	14.2	3.10	17.6	1.95
80	10.5	7.00	13.5	6.50	15.2	3.90	11.7	3.80	16.5	3.10	19.8	1.95
78	12.7	7.00	15.7	6.50	17.2	3.90	14.2	3.80	18.8	3.10	21.9	1.95
75	16.1	7.00	18.8	6.20	20.1	3.75	17.8	3.80	22.1	2.90	24.9	1.85
73	18.2	7.00	20.7	5.80	22.0	3.65	20.1	3.80	24.2	2.80	26.9	1.80
70	21.3	6.50	23.6	5.25	24.8	3.50	23.6	3.80	27.4	2.65	29.7	1.74
68	23.2	6.00	25.4	4.90	26.6	3.45	25.8	3.70	29.4	2.55	31.6	1.70
65	26.0	5.20	28.1	4.45	29.2	3.35	28.9	3.40	32.3	2.45	34.3	1.64
63	27.8	4.80	29.9	4.20	30.9	3.30	30.9	3.25	34.3	2.40	36.0	1.61
60	30.3	4.15	32.3	3.70	33.3	3.20	33.9	3.05	37.0	2.35	38.5	1.57
58	32.0	3.80	33.9	3.40	34.8	3.15	35.8	2.95	38.8	2.30	40.1	1.55
55	34.3	2.80	36.0	2.55	36.9	2.40	38.4	2.35	41.2	2.00	42.3	1.53
53	35.7	2.25	37.4	2.05	38.2	1.95	39.9	1.90	42.6	1.60	43.8	1.45
50	37.8	1.55	39.4	1.40	40.0	1.30	42.1	1.25	44.7	1.05	45.6	0.95
48	39.1	1.15	40.6	1.05	41.2	0.95	43.6	0.90				
(°)	47 ~ 81.5		47 ~ 81.5		47 ~ 81.5		47 ~ 81.5		49 ~ 81.5		49 ~ 81.5	

Unit: ton

C D	47.5m Boom + 21.0m Jib					
	5 °		25 °		45 °	
E (°)	B (m)	M	B (m)	M	B (m)	M
81.5	10.6	2.50	17.4	1.85	22.2	1.00
80	13.2	2.50	19.9	1.85	24.4	1.00
78	15.9	2.50	22.4	1.85	26.6	1.00
75	19.8	2.50	25.9	1.75	29.8	1.00
73	22.4	2.50	28.2	1.65	31.9	1.00
70	26.2	2.50	31.5	1.55	34.9	1.00
68	28.6	2.50	33.6	1.50	36.8	0.98
65	32.0	2.25	36.8	1.45	39.6	0.94
63	34.2	2.10	38.8	1.40	41.4	0.92
60	37.4	1.95	41.7	1.35	43.9	0.90
58	39.4	1.85	43.6	1.30	45.5	0.89
55	42.4	1.70	46.2	1.26	47.8	0.87
53	44.2	1.60	47.9	1.23	49.3	0.86
50	46.6	1.00				
48						
(°)	49 ~ 81.5		52 ~ 81.5		52 ~ 81.5	

B= Working radius C= Jib length D= Jib offset

E= Boom angle M= Total rated loads

= Boom angle range (for the unladen condition)

[JIB]

Performance D

Unit: ton

C D	47.5m Boom + 9.8m Jib						47.5m Boom + 15.4m Jib					
	5 °		25 °		45 °		5 °		25 °		45 °	
E (°)	B (m)	M	B (m)	M	B (m)	M	B (m)	M	B (m)	M	B (m)	M
81.5	8.2	7.00	11.3	6.50	13.2	3.90	9.3	3.80	14.2	3.10	17.6	1.95
80	10.5	7.00	13.5	6.50	15.2	3.90	11.7	3.80	16.5	3.10	19.8	1.95
78	12.7	7.00	15.7	6.50	17.2	3.90	14.2	3.80	18.8	3.10	21.9	1.95
75	16.1	7.00	18.8	6.20	20.1	3.75	17.8	3.80	22.1	2.90	24.9	1.85
73	18.2	7.00	20.7	5.80	22.0	3.65	20.1	3.80	24.2	2.80	26.9	1.80
70	21.3	6.50	23.6	5.25	24.8	3.50	23.6	3.80	27.4	2.65	29.7	1.74
68	23.2	6.00	25.4	4.90	26.6	3.45	25.8	3.70	29.4	2.55	31.6	1.70
65	25.7	4.40	27.9	3.85	29.2	3.35	28.9	3.40	32.3	2.45	34.3	1.64
63	27.3	3.45	29.5	3.05	30.7	2.75	30.8	2.85	34.3	2.35	36.0	1.61
60	29.7	2.30	31.7	2.00	32.9	1.85	33.3	1.90	36.6	1.55	38.4	1.30
58	31.3	1.65	33.2	1.45	34.3	1.30	35.0	1.35	38.2	1.05		
(°)	57 ~ 81.5		57 ~ 81.5		57 ~ 81.5		57 ~ 81.5		57 ~ 81.5		59 ~ 81.5	

Unit: ton

C D	47.5m Boom + 21.0m Jib					
	5 °		25 °		45 °	
E (°)	B (m)	M	B (m)	M	B (m)	M
81.5	10.6	2.50	17.4	1.85	22.2	1.00
80	13.2	2.50	19.9	1.85	24.4	1.00
78	15.9	2.50	22.4	1.85	26.6	1.00
75	19.8	2.50	25.9	1.75	29.8	1.00
73	22.4	2.50	28.2	1.65	31.9	1.00
70	26.2	2.50	31.5	1.55	34.9	1.00
68	28.6	2.50	33.6	1.50	36.8	0.98
65	32.0	2.25	36.8	1.45	39.6	0.94
63	34.2	2.10	38.8	1.40	41.4	0.92
60	37.1	1.55	41.6	1.15		
58						
(°)	59 ~ 81.5		59 ~ 81.5		62 ~ 81.5	

B= Working radius C= Jib length D= Jib offset
E= Boom angle M= Total rated loads
= Boom angle range (for the unladen condition)

[JIB]

Performance E

Unit: ton

C D	47.5m Boom + 9.8m Jib						47.5m Boom + 15.4m Jib					
	5 °		25 °		45 °		5 °		25 °		45 °	
E (°)	B (m)	M	B (m)	M	B (m)	M	B (m)	M	B (m)	M	B (m)	M
81.5	8.2	7.00	11.3	6.50	13.2	3.90	9.3	3.80	14.2	3.10	17.6	1.95
80	10.5	7.00	13.5	6.50	15.2	3.90	11.7	3.80	16.5	3.10	19.8	1.95
78	12.7	7.00	15.7	6.50	17.2	3.90	14.2	3.80	18.8	3.10	21.9	1.95
75	16.1	7.00	18.8	6.20	20.1	3.75	17.8	3.80	22.1	2.90	24.9	1.85
73	18.2	7.00	20.7	5.80	22.0	3.65	20.1	3.80	24.2	2.80	26.9	1.80
70	21.3	6.50	23.6	5.25	24.8	3.50	23.6	3.80	27.4	2.65	29.7	1.74
68	23.1	5.50	25.4	4.75	26.6	3.45	25.8	3.70	29.4	2.55	31.6	1.70
65	25.6	3.85	27.8	3.40	29.1	3.10	28.9	3.25	32.3	2.45	34.3	1.64
63	27.2	3.00	29.3	2.60	30.6	2.40	30.6	2.50	34.1	2.05	36.0	1.61
60	29.6	1.90	31.6	1.65	32.8	1.50	33.2	1.55	36.5	1.25	38.3	1.05
58	31.1	1.30	33.1	1.15	34.2	1.00	34.8	1.05				
(°)	57 ~ 81.5		57 ~ 81.5		57 ~ 81.5		57 ~ 81.5		59 ~ 81.5		59 ~ 81.5	

Unit: ton

C D	47.5m Boom + 21.0m Jib					
	5 °		25 °		45 °	
E (°)	B (m)	M	B (m)	M	B (m)	M
81.5	10.6	2.50	17.4	1.85	22.2	1.00
80	13.2	2.50	19.9	1.85	24.4	1.00
78	15.9	2.50	22.4	1.85	26.6	1.00
75	19.8	2.50	25.9	1.75	29.8	1.00
73	22.4	2.50	28.2	1.65	31.9	1.00
70	26.2	2.50	31.5	1.55	34.9	1.00
68	28.6	2.50	33.6	1.50	36.8	0.98
65	32.0	2.25	36.8	1.45	39.6	0.94
63	34.2	2.10	38.8	1.40	41.4	0.92
60	36.9	1.25				
58						
(°)	59 ~ 81.5		62 ~ 81.5		62 ~ 81.5	

B= Working radius C= Jib length D= Jib offset
 E= Boom angle M= Total rated loads
 = Boom angle range (for the unladen condition)

[JIB]

Performance F

Unit: ton

C	47.5m Boom + 9.8m Jib						47.5m Boom + 15.4m Jib					
	5 °		25 °		45 °		5 °		25 °		45 °	
D	B (m)	M	B (m)	M	B (m)	M	B (m)	M	B (m)	M	B (m)	M
E (°)												
81.5	8.2	7.00	11.3	6.50	13.2	3.90	9.3	3.80	14.2	3.10	17.6	1.95
80	10.5	7.00	13.5	6.50	15.2	3.90	11.7	3.80	16.5	3.10	19.8	1.95
78	12.7	7.00	15.7	6.50	17.2	3.90	14.2	3.80	18.8	3.10	21.9	1.95
75	16.1	7.00	18.8	6.20	20.1	3.75	17.8	3.80	22.1	2.90	24.9	1.85
73	18.1	6.25	20.6	5.20	22.0	3.65	20.1	3.80	24.2	2.80	26.9	1.80
70	20.6	4.05	23.0	3.40	24.7	3.00	23.4	3.35	27.4	2.60	29.7	1.74
68	22.3	2.95	24.7	2.45	26.2	2.20	25.2	2.40	29.1	1.85		
(°)	67 ~ 81.5		67 ~ 81.5		67 ~ 81.5		67 ~ 81.5		67 ~ 81.5		69 ~ 81.5	

Unit: ton

C	47.5m Boom + 21.0m Jib					
	5 °		25 °		45 °	
D	B (m)	M	B (m)	M	B (m)	M
E (°)						
81.5	10.6	2.50	17.4	1.85	22.2	1.00
80	13.2	2.50	19.9	1.85	24.4	1.00
78	15.9	2.50	22.4	1.85	26.6	1.00
75	19.8	2.50	25.9	1.75	29.8	1.00
73	22.4	2.50	28.2	1.65	31.9	1.00
70	26.2	2.50	31.5	1.55	34.9	1.00
68	28.3	1.95				
(°)	67 ~ 81.5		69 ~ 81.5		69 ~ 81.5	

B= Working radius C= Jib length D= Jib offset
 E= Boom angle M= Total rated loads
 = Boom angle range (for the unladen condition)

WORKING RADIUS - LIFTING HEIGHT

Performance A
 With 22t counterweight
 Outriggers fully extended

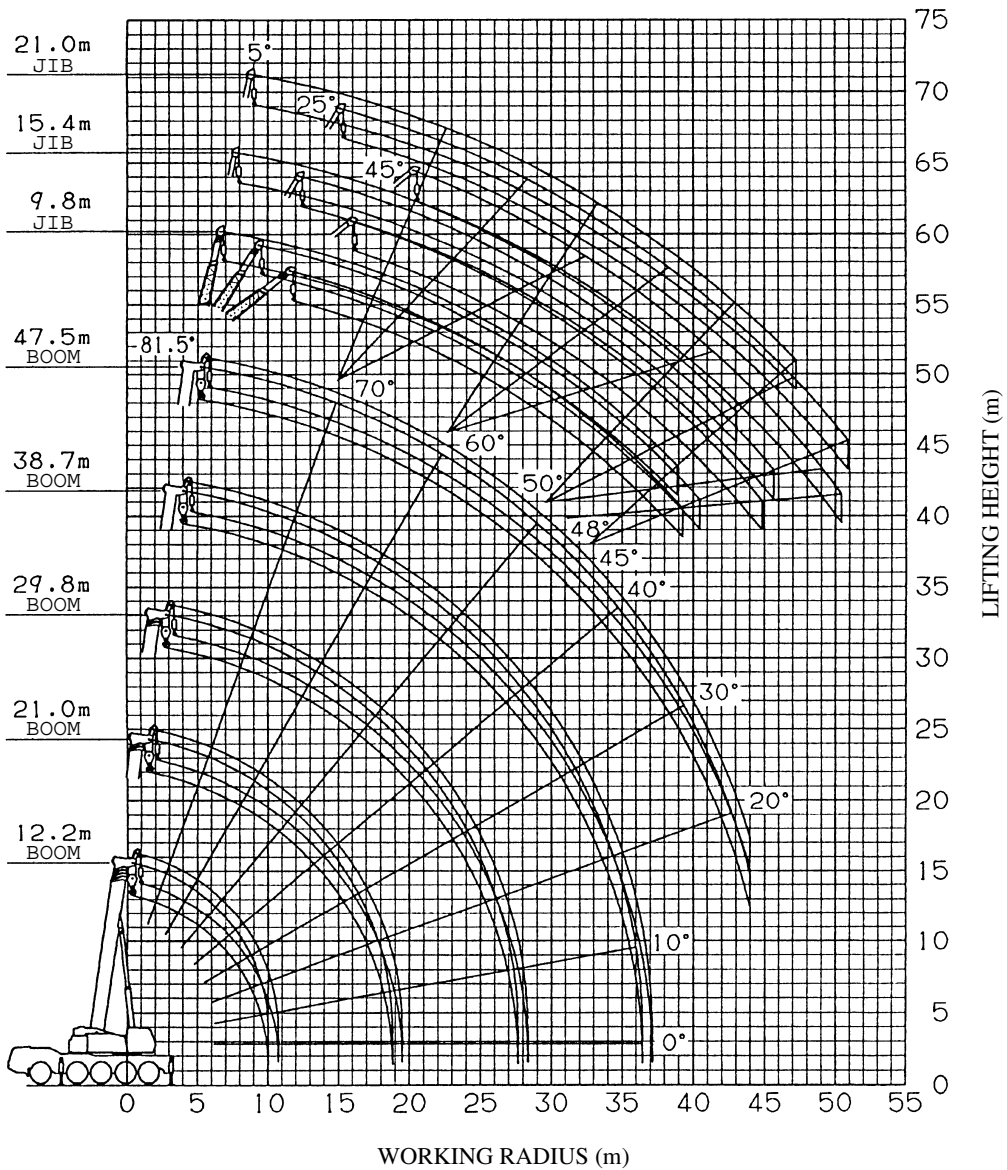

NOTES:

1. The deflection of the boom is not incorporated in the figure above.
2. The above figure is for the boom "telescoping method I".

DIMENSIONS (1/100)

[On public thoroughfare traveling condition]

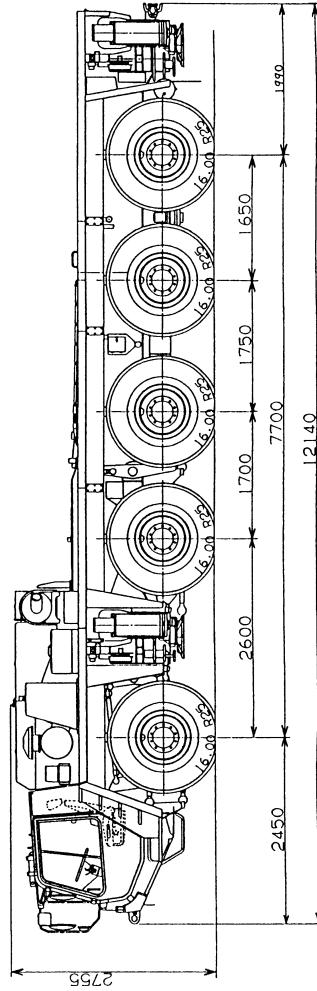
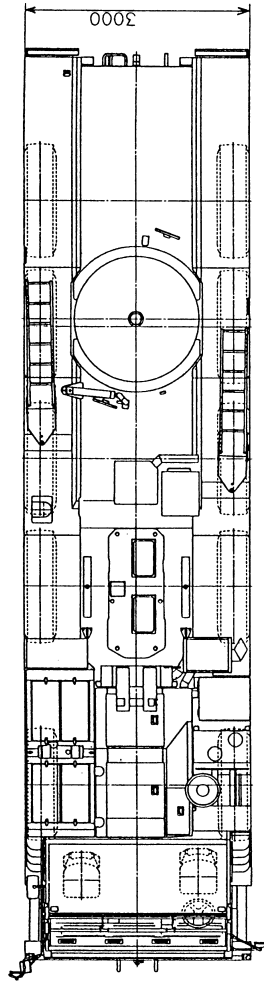

DIMENSIONS (1/100)

[On-site traveling condition]

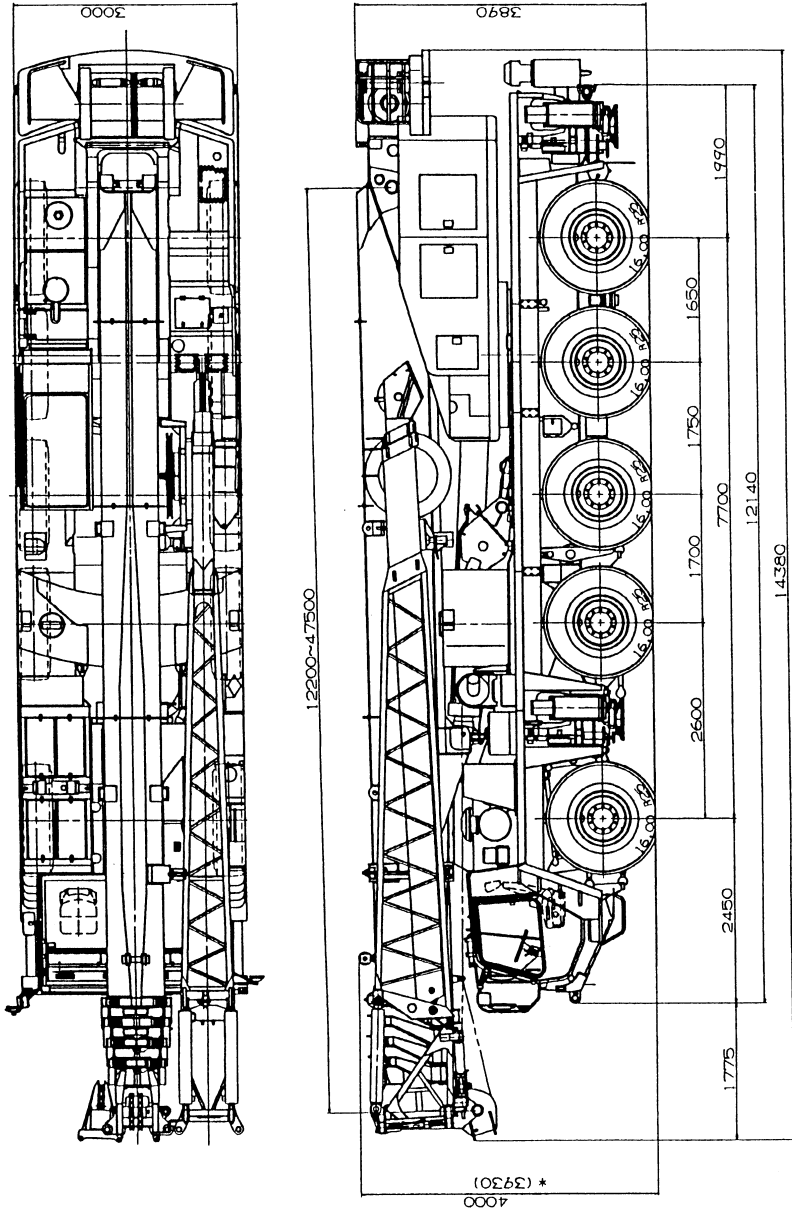

*-marked dimension: when the guide sheave is removed from the top surface of the base boom section.