

HITACHI SUMITOMO

SCX2500LF

HYDRAULIC CRAWLER CRANE

Specifications

EUROPEAN ISSUE

Specifications

HITACHI SUMITOMO

SCX2500LF

Superstructure

UPPER REVOLVING FRAME:

All-welded, precision machined, robust construction. A machined surface provided for mounting load hoist and boom hoist assemblies, and mounting itself on turntable bearing.

TURNTABLE BEARING WITH INTERNAL SWING GEAR:

Heavy duty, single shear ball type; inner race of turntable bearing with integral, internal swing (ring) gear bolted to carbody frame, and outer race of turntable bearing bolted to upper revolving frame.

CONTROL SYSTEM:

System contains two sets of triplicate tandem valves which direct oil to various machine function and are actuated by control levers via remote controlled hydraulic servo for all motions. Working speeds can be precisely controlled by motorcycle type throttle and pilot-operated arm chair single axis control levers in cooperation with "SC" controller that varies engine rpm and hyd. pump discharge simultaneously, or varies just hyd. pump discharge while keeping engine rpm. System also takes unique EEP SA (Electrical Engine Pump Sensing Analyzer) to maximizes drum horsepower, and reduces horsepower loss with eliminating the possibility of engine stall.

Pump control system — By "SC" controller that provides two modes of engine-pump control.

MODE I:

The SC Controller is normally programmed to vary the engine speed and pump discharge simultaneously. Simply twisting the grip advances the engine to maximum speed and the hydraulic pumps to maximum flow at the same time. This mode is suitable to precision crane work.

MODE II:

By activating a switch, it is able to vary just the pump discharge by means of the grip throttle, while keeping engine speed fixed. Mode II is convenient for operations such as lifting magnet and bucket work, where the engine is normally run at full throttle.

HYDRAULIC SYSTEM:

System provided with three variable displacement axial piston pumps and one fixed displacement duplicate tandem gear pump for both independent and combined operations of all functions. Gear pump also used for system valves and cylinder controls.

Main/aux. crane hoist motors — Variable displacement axial piston motor with counterbalance valve and spring-applied/hydraulically released multiple wet-disc type automatic brake.

Boom hoist motor — Two; axial piston type with counterbalance valve and spring-applied/hydraulically released multiple wet-disc type automatic brake.

Luffing jib hoist drum motor — Optional extra; axial piston type with counterbalance valve and spring-applied/hydraulically released multiple wet-disc type automatic brake; required when machine is operated with luffing towercrane attachment.

Swing motor — Two; axial piston type with spring-applied/hydraulically released multiple wet-disc type manually controlled brake.

Travel motors — Shoe-in design; axial piston motor

with brake valve and spring-applied/hydraulically released multiple wet-disc type automatic brake.

Oil cooler — Located at right-rear of machinery room as separated from engine radiator together with an independent autocooling fan for better cooling efficiency and heat balance.

Independent hyd. circuits — Available in between hydraulic circuits of P1 main pump and front main drum winch motor, and between P2 main pump and rear main drum winch motor.

Hydraulic oil reservoir — 410 liters capacity.

LOAD HOIST ASSEMBLY:

Front and rear main operating drums driven by independent hydraulic motor of bi-directional, variable displacement axial piston motor through 2-stage planetary reduction gear units powering the rope drum in either direction for hoisting and lowering load. Each of drum sized in same dimension.

Brakes — Spring-applied, power hydraulically released multiple wet-disc type automatic brake; provided within hyd. motor;

Clutches — Optional extra; internal expanding, self-adjusting, mono-band design with non-asbestos lining; spring-applied, power hydraulically released. Available for a true gravity free-fall operation in functional cooperation with optional “ external contracting band type brakes ”.

External contracting band type brakes — Optional extra; required together with optional “ clutches ” for a true gravity free-fall operation. Instead of standardized automatic brake, an external contracting band type brake with 1,270mm dia. by 170mm wide brake drum with non-asbestos lining operated by power hydraulically assisted foot pedal with locking latch is designed. Two brake modes are available; for crane operation, automatic brake, spring-applied, power hydraulically released is applied when control lever is in neutral position, and for bucket operation, free-fall is available in the above control lever position.

Drums — One piece, parallel grooved lagging with locking ratchet wheel cast integral; mounted on drum shaft through anti-friction bearings.

Drum locks — Power hydraulically operated automatic pawl as std. while electrically controlled pawl is designed i/o automatic in a case of two main operating drums with optional free-fall function.

Drum rollers — Optional extra; available for right cable winding onto drums.

BOOM HOIST ASSEMBLY:

Twin-drum design; driven by two bi-directional, axial piston hydraulic motor through 2 sets of 2-stage planetary reduction gear unit powering the rope drum in either direction for hoisting and lowering boom.

Brake — Spring-applied, power hydraulically released multiple wet-disc type automatic brake.

Drum — One piece, twin-designed parallel grooved with locking ratchet wheel cast integral; bolted to planetary reduction gear unit outer cased of hyd motors.

Drum lock — Power hydraulically operated automatic pawl.

LUFFING JIB HOIST DRUM WINCH MECHANISM:

Optional extra; driven by bi-directional, axial piston hydraulic motor through 2-stage planetary reduction gear unit powering the rope drum in either direction for hoisting and lowering tower jib; required when machine is operated with luffing towercrane attachment.

This third drum winch mechanism mounted within tower boom bottom section for more safety and easy erection work of luffing towercrane attachment.

Brake — Spring-applied, power hydraulically released multiple wet-disc type automatic brake; provided within hydraulic motor.

Drum — One piece, parallel grooved lagging with locking ratchet wheel cast integral; bolted to planetary reduction gear unit outer case of hyd. motor.

Drum lock — Power hydraulically operated automatic pawl.

SWING:

Driven by two units of bi-directional, axial piston hydraulic motors through 2 sets of planetary reduction gear unit powering swing pinion. Swing pinion meshes with internal teeth of swing (ring) gear of turntable bearing inner race.

Brakes — Spring-applied, power hydraulically released multiple wet-disc type; provided on each of hydraulic motor.

Swing speed control — Max. swing speed can be tuned according to arbitrary value that is electrically controlled by dialing, and then varies pump discharge.

Lock — Mechanically operated drop pin.

Speed — 1.7min.^{-1} $<1.7\text{rpm}>$

GANTRY:

A-frame type; raised and lowered by power hydraulic cylinders.

OPERATOR'S CAB:

Swing-away design to set a 3.19-meter overall width of superstructure for a good transport; 940mm wide; acoustically treated, all new stamped, automotive type, full-vision, cushion rubber mounted, well-ventilated, full compartment, roomy operator's cab with large curved front window; provided with an arrangement of “SC” control/swing lever, sunvisor, sunshade, rear-view mirrors, intermittent dual window shield wipers with washer on both front and roof windows, and roll-down window on sliding door.

Instrument panel — Contains engine monitoring lamps, display panel of SML-10 Load Moment Limiter, and other necessary controllers and switches.

Operator's seat — Full adjustable reclining seat.

Air-conditioner — Optional extra;built-in type full air-conditioning.

Heater — Optional extra;hot water type.

Anemometer — Analogue type; provided with a function of warning buzzer when wind velocity exceeds 10 m/s.

Stone guard — Optional extra; stainless steel-make. This is available for operator's cab protection from outside obstacles.

AM/FM radio — Provided as std. with clock.

Fire extinguisher — Optional extra; powder type with 1kg capacity.

MACHINERY CAB:

Equipped with hinged doors on both sides for machinery access and inspection; tape-type non-skid material applied to the roof.

CATWALKS:

Optional extra; hitched in place along both sides of machinery cab.

HYDRAULIC TAGLINE WINDER:

Optional extra; provided in front of upper revolving frame, and this is available for preventing a shake of suspended load like clamshell bucket by an 10mm dia. tug cable with light force.

COUNTERWEIGHTS:

Weighs 93.7ton consisting of a 12.3ton steel base plate, 6ton steel plate and 8 blocks of cast, removable, corner-rounded design which consist of "A" (10,900kg), "B" (10,900kg), "C" (10,800kg), "D" (10,800kg), "E" (8,500kg), "F" (8,100kg), "G" (7,900kg) and "H" (7,500kg).

Note: A 6ton steel plate must be deducted when boom length does not exceed 21.35m in the case of liftcrane application.

ELECTRICAL SYSTEM:

24-volt negative ground system; provided with two maintenance free 12-volt batteries.

LIGHTING SYSTEM:

Includes following lights.

- Two 70 W working lights;
- One 10 W interior cab light.

POWER UNIT:

Make & Model	Mitsubishi 6D24-TL*
Type	Water-cooled, 4-cycle, direct injection, turbo-charged, diesel w/automatic cooling fan
No. of Cylinders	Six (6)
Bore & Stroke	130 mm × 150 mm
Displacement	11,945 cc
Rated Output	235 kW/2,000 min ⁻¹ 320 ps/2,000 rpm
Maximum Torque	1,245 N·m/1,400 min ⁻¹ 127 kgf·m/1,400 rpm
Fuel Tank	500 liters

*Two kinds of engine models are available in accordance with applications to int'l smoke emission legislations; one is 6D24-TLU2E for EU Emission Regulations for Off-Road Diesel Engines-Stage 2, and the other is 6D24-TLE2A for Japanese Emission Standards of Diesel Construction Equipment-Stage 2.

A PORTABLE ENGINE-HYDRAULIC POWER PACK:

Optional extra; available to supply power hydraulic to hydraulic cylinders as used as rear post backstops. Required when luffing towercrane att.

Undercarriage

CARBODY FRAME:

All-welded, precision machined, box type construction; provided with four tip blocks w/pins and lugs to hook and then assemble crawler side frames on. To mount turntable bearing, a machined surface is provided too.

Hyd. removal joint-pins — Four; available to hold in place crawler side frames on carbody frame with a face-contact design to bear reaction force of crawler side frame. And, four pins are each operated by hyd. cylinder.

CARBODY JACK-UP DEVICE:

Contains four hydraulic jack cylinders attached on carbody jack cylinder beams for disassembling/assembling ease of crawler side frames.

Pontoon — All-welded construction; four pontoons each stored at an inside part of jack cylinder beams.

CRAWLER SIDE FRAMES:

All-welded, box type construction, precision machined; each provided with two steel plate hooks for an assembling ease on carbody frame. Held in place by hydraulic removal heavy duty joint-pins provided on four tip blocks of carbody frame.

Crawler side steps — Provided at both ends of the frames for easy access to superstructure.

CARBODY WEIGHT:

Weighs 14ton; made of steel scrap with concrete pouring. 7ton each mounted at front and rear of the carbody.

DRIVE SPROCKETS:

Cast steel, heat treated; one per side frame. Track drive sprocket assembly bolt-coupled to 3-stage planetary reduction gear unit outer case as an integral part of shoe-in type traction motor. Sealed between parts of rotation and non-rotation of the motor with floating seal.

IDLER WHEELS:

Cast steel, heat treated; one per side frame. Mounted on two bronze bushings with floating seals for lifetime lubrication.

TRACK ROLLERS:

Fifteen per side frame; each heat treated cast steel with double flange design. All rollers mounted on two bronze bushings with floating seals for lifetime lubrication.

CARRIER ROLLERS:

Four per side frame; each heat treated cast steel. Two rollers are double flanged while other two rollers are single flanged type. All rollers mounted on bronze bushing(s) with floating seals for lifetime lubrication.

TRACKS:

Heat treated, self-cleaning, multiple hinged track shoes joined by full floating pins; 58 pcs. per side frame.

Shoe width — 1,120mm wide as standard.

Track adjustment — Manual adjustment device with oil jack and shim plate packs is standardized.

Automatic track tension adjusting device — Optional extra; available instead of std. track adjustment to always keep track tension at optimum level by means of power hyd. cylinder thru idler wheel actuated by power hydraulic supplied from superstructure.

TRAVEL AND STEERING:

A bi-directional, shoe-in type axial piston hydraulic motor bolt-couples drive sprocket thru 3-stage planetary reduction gear unit outer case at each crawler side frame end for travel and steer. Straight-line travel (forward or reverse), pivot or differential turns, and counter-rotation for spin turns are available.

Brake — Spring-applied, hydraulically released multiple wet-disc type automatic brake; located within hydraulic motor. Brakes automatically set when travel levers are in neutral or when engine is shut down.

Travel speed — 1.2/0.8km/hr. (based on flat, level and firm supporting surface, and under the conditions that no load must be applied and front-end att. must be 15.25m basic boom only).

Gradeability — 30% (17°) permissible based on basic machine without front-end attachment.

DRUM ROPE OVER-PAYOUT PREVENTING DEVICE:

Available on both front and rear main drums, and functions to automatically stop drum rotation when no. of rope winding at 1st layer becomes three(3).

NON FREE-FALL OPERATION SWITCH:

Optional extra; this is standardized when opt. free-fall function on two main drums is designed, and available for keeping non free-fall operation during operation when it is necessary. Provided with key for switch on-off control.

HOOK OVER-HOIST LIMITING DEVICE:

Limit switch type. Available to prevent hook over-hoisting with functions of automatic drum braking with hydraulic lock, and warnings by red lamp and annunciating alarm.

BOOM OVER-HOIST AND -LOWERING LIMITING DEVICE:

Available in two kinds of devices; one is limit switch located on a part of boom foot for preventing boom over-hoisting, and the other is the safety function of the SML-10 available to automatically prevent boom over-hoisting and -lowering with the functions of automatic drum braking with hydraulic lock, and warnings by red lamp and annunciating alarm. Further boom protection from rapid boom over-hoist by hook over-hoist motion under mal-function of hook over-hoist limiting device is available as one of functions of the SML-10.

BOOM BACKSTOPS:

Dual; telescopic design with spring buffers.

DUAL BOOM OVER-HOIST LIMITING DEVICE:

Additional limit switch located on boom backstops; this is as a further safety device for redundant boom protection.

SWING LOCK:

Mechanically operated drop pin; available to firmly lock superstructure in four positions of facing front or rear or left or right to undercarriage.

DRUM LOCKS:

Power hydraulically operated pawl lock is available on front, rear and boom hoist drum with an automatic locking device as std. while electrically controlled pawl locks is designed on front and rear main drums i/o automatic in case that free-fall function is required.

BOOM ANGLE INDICATOR:

Pendulum type; mounted on right-hand side of bottom section of crane main boom.

HOOK LATCH:

Provided on every kinds of hook to prevent out of place of cable from hook.

LEVEL GAUGE:

Bubble type; located on operator's cab floor and a part of undercarriage.

LEVER LOCKS:

Provided on all control levers (except swing lever) to lock levers in neutral.

Safety Devices

SML-10 LOAD MOMENT LIMITER:

This is a fully computerized total safe operation control system, and automatic over-load preventing system as standard equipment. The SML-10 meets EN Standards.

Construction (standard version) — Comprises (1) load detecting device, (2) boom angle detector, and (3) display panel with computerized Micro processing Unit (M.P.U).

Functions — This system functions that if a lifting load reaches a 90% of the rated one specified in the crane capacity chart, an annunciating pre-warning is given; if it is an 100%, a warning is given by red lamp, and annunciating warning, and all peril side motions are automatically stopped. The machine, however, can be operated in safety side motions.

Display panel design — The SML-10 is designed to be able to input the operating conditions/data by setting keys on LCD 1, and to indicate the present lifting conditions/data like "lifting load" "rated load", "working radius" "boom angle", and so forth on LCD 2 thru LCD 5. Also, the LCD 1 indicates "engine rpm", "load ratio" and "lifting height (opt.)". In addition, the LCD 1 indicates letter messages when the machine becomes abnormal.

SWING ALARM:

This is by buzzer, and flasher lamps located on both sides of machinery cab.

WARNING ALARMS:

This is one of functions of the SML-10; provided with some kinds of different audible alarms to let operator know the operation limit.

SPEED SLOWDOWN DEVICE:

This is for speed slowdown of hoisting and lowering motions of crane main boom which are available just before automatic stopping to prevent a shock.

SWING BRAKE LAMP:

Provided on operator's cab instrument panel; this is available to confirm whether or not swing brake is applied.

SIGNAL HORN:

Available as warning just before every kinds of motions from operator.

FOOL PROOF SHUT-OFF SYSTEM:

Located in the cab exit; this is available to automatically deactivate and lock hydraulic system.

TRAVEL ALARM:

Buzzer warns when travel motion is initiated.

ENGINE MONITORING LAMPS:

Available for checking engine operating conditions like battery charge, engine oil pressure, radiator coolant level, oil filter clogging, air filter clogging, and battery electrolyte amount.

EMERGENCY MACHINE STOP BUTTONS:

Two; each located nearby front main and boom hoist drums. Available when it is necessary to stop all machine motion.

REAR VIEW MIRRORS:

Two each provided on front-left and -right corners of superstructure.

THREE COLOR PERCENTAGE INDICATOR:

Optional extra; this is with three colours of Green, Yellow and Red. Each colour indicates the load percentage to rated capacity; Green shows less than 90% as safety, Yellow shows 90 to 99% as marginal, and Red shows over 100% as over-loading. As further function, Red lamp comes on automatically when operator cuts off safety device switch absent-mindedly.

LIFTING HEIGHT METER:

Optional extra; available to indicate lifting height above ground or depth below ground on display "LCD 1" of SML-10 Load Moment Limiter display panel. Also, hook hoisting speed slowdown function is available just before automatic stopping at a desired height under hook heightsetting before operation.

MICROPHONE & LOUD-SPEAKER:

Optional extra; this is for operator's convenience for loud speaking.

DRUM LIGHT & MIRROR:

Optional extra; these are available for checking rope winding onto front and/or rear drum(s).

AUX. CRANE HOOK OVER-HOIST LIMITING DEVICE:

Optional extra; this is available for auxiliary crane hoist with optional aux. short jib and/or fly jib. Performs the same function as that of "Hook over-hoist limiting device" mentioned before.

In addition to the above, following safety devices are standard for luffing towercrane attachment.

LUFFING JIB ANGLE DETECTOR:

This is one of key safety device in a case of luffing towercrane attachment.

LUFFING TOWERCRANE LOAD DETECTOR:

This is also important safety device when luffing towercrane attachment is required.

LUFFING JIB OVER-HOIST AND -LOWERING LIMITING DEVICE:

Performs all the same function as that of "Boom over-hoist and -lowering limiting device" stated before.

LUFFING JIB HOOK OVER-HOIST LIMITING DEVICE:

Performs the same function as that of "Hook over-hoist lifting device" described before.

LUFFING TOWERCRANE ATT. SELF-ERECTION MODE:

This is an internal, integral mode as one of key function of the SML-10 for safe self-erection and -laying down of luffing towercrane attachment without fail.

LUFFING JIB BACKSTOPS:

Dual; telescopic design with spring buffers.

DUAL LUFFING JIB OVER-HOIST LIMITING DEVICE:

Additional limit switch located on tower jib backstops; this is as a further safety device for redundant tower jib protection.

LUFFING JIB HOIST DRUM LOCK:

Provided with automatic pawl-locking device like other drum pawl-locking.

REAR POST BACKSTOPS:

Two power hydraulic cylinders are designed to easily set rear post position as necessary when assembling front post and luffing jib; power hydraulic is supplied to these cylinders by a portable engine-hydraulic power pack.

Front-end Attachment

CRANE BOOM:

Lattice construction, round tubular main chords, alloy, hi-ten steel, with bracing of round steel tubing.	
Boom connections	In-line pin connections at 2.10m deep and 2.10m wide for ultra heavy- and heavy-duty booms, and 1.55m deep 1.55m wide for light-duty booms.
Basic boom	Three-piece, 15.25m basic length; 7.62m heavy-duty bottom section, 7.24m heavy-duty tapered extension, and 0.38m hammer-head top section. Provided with boomfoot pin removal cylinders.
Boom head machinery	Five head sheaves, and two guide sheaves mounted on anti-friction bearings.
Five-hanger sheave block	Optional extra; pinned to boom head shaft. Five sheaves each mounted on anti-friction bearings. Required when lifting load exceeds 135ton, and available up to 250ton lift.
Three-hanger sheave block	Optional extra; pinned to boom head shaft. Three sheaves each mounted on anti-friction bearings. Required when lifting load exceeds 135ton, and available up to 200ton lift.
Heavy-duty boom extensions	Optional extra; available in 3.05m, 6.10m and 9.15m with pendants.
Ultra heavy-duty boom extension	Optional extra; available in 9.15m with pendants.
Tapered boom extensions	Optional extra; available in 4.55m with pendants and mid-point link.
Light-duty boom extensions	Optional extra; available in 3.05m, 6.10m and 9.15m length with pendants.
Light-duty tapered top section	Optional extra; available in 9.15m with pendants. Provided with a 3-nylon sheave machinery, and a 2-steel plate wheel.
Maximum boom length	88.40m (under configuration of ultra heavy-duty, heavy-duty and light-duty boom extensions with a 9.15m light-duty tapered top section). 70.1m (under configuration of ultra heavy-duty and heavy-duty boom extensions only with a 0.38m hammer-head top section).

Note: All of ultra heavy- and heavy-duty boom extensions are designed with no intermediate diagonal bracing(s); the diagonal bracing is only designed at picture frame at both ends, and one of the two is detachable. Accordingly, it is able to nest light-duty boom extension into appropriate heavy-duty boom extension in length.

FLY JIB:

Optional extra; lattice construction, round tubular main chords, alloy, hi-ten steel, with bracing of round steel tubing having in-line pin connections at 1.0m deep and 1.0m wide, and jib head machinery with single sheave mounted on anti-friction bearings. Provided with jib strut, jib backstops, and jib/boom guyline pendants. Mounted on 0.38m hammer-head top section, and available for light load lifting operation with less than 27ton with two-part hoist line. Single part hoist line is also available for a 13.5ton lift as max.	
Basic fly jib	Two-piece, 12.20m basic length; 6.10m bottom and top sections.
Fly jib extensions	Available in 6.10m length with pendants.
Maximum fly jib length	36.55m.
Boom plus fly jib length	Max. 70.1m(with 0.38m hammer-head top section)+36.55m.

AUXILIARY SHORT JIB:

Optional extra; all-welded construction having single sheave head machinery. Pinned to 0.38m hammer-head top section.

HOOK BLOCKS:

250/135t, five sheaves plus 5-hanger sheave block with duplex type hook	Optional extra.
200/135t, five sheaves plus 3-hanger sheave block with duplex type hook	Optional extra.
135t, five sheaves with duplex type hook	Optional extra.
80t, three sheaves	Optional extra.
35t, one sheave	Optional extra.
13.5t, ball hook	Optional extra.

Notes: An 135t hook block is each available from 200/250t hook block by dismantling a 3/5-hanger sheave block.

BAIL AND BRIDLE:

All-welded construction; provided with larger sheaves of a 21.4 D/d ratio on both bail and bridle for 2x8-part boom hoist rope reeving. Bail pinned to A-frame gantry, and bridle suspended between a 2x8-part boom hoist rope and pendant ropes connecting to tip of 0.38m hammer-head top section or 9.15m light-duty tapered top section.

DRUM DATA:

Drum	Root dia.	Type	Line speed (Hoisting, Lowering)	Cable	Max. line pull
Front main	576mm	Parallel grooved	120 ~ 2mpm	28mm	245kN (25.0ton)
Rear main	576mm	Parallel grooved	120 ~ 2mpm	28mm	245kN (25.0ton)
Boom hoist	504mm	Parallel grooved	2 x (24 ~ 1.0) mpm	22.4mm	165kN (16.9ton) x 2
Luffing jib hoist (opt.)	526.4mm	Parallel grooved	50 ~ 2mpm	22.4mm	145kN (14.8ton)

Notes:

- Line speed is based on drum first layer and rated engine rpm.
- Hoisting line speed varies under load and operating conditions.
- Crane hoist applications of front and rear main drums shall be upon kind of front-end attachment.

HOIST REEVING:

		(ton)														
hook	No. of partline	20	18	16	14	12	10	9	8	7	6	5	4	3	2	1
	250t		250.0	230.0	209.0	186.0	162.0	—	—	—	—	—	—	—	—	—
200t		—	—	200.0	186.0	162.0	—	—	—	—	—	—	—	—	—	—
135t		—	—	—	—	—	135.0	121.5	108.0	94.5	81.0	67.5	54.0	40.5	27.0	13.5
80t		—	—	—	—	—	—	—	—	—	80.0	67.5	54.0	40.5	27.0	13.5
35t		—	—	—	—	—	—	—	—	—	—	—	—	35.0	27.0	13.5
13.5t		—	—	—	—	—	—	—	—	—	—	—	—	—	—	13.5

CABLES:

- Front drumP-S (19)+39×P-7, non-spin type, 28mm dia./410m long, breaking load 755kN (77.0t). This cable with 410m long is available for both of main crane hoist in liftcrane att., and luffing jib foot crane hoist in luffing towercrane att. while a 350m long cable is logically required for luffing jib foot crane hoist.
- Rear drumOptional extra; P-S (19)+39×P-7, non-spin type, 28mm dia., breaking load 755kN (77.0t).
Length depends on crane hoist applications as under:
 1. Luffing jib application.....410m.
 2. Fly jib application.....290m.
 3. Aux. short jib application.....150m.
- Boom hoist drumXP rope with construction of IWRC 6×P·WS (31), 22.4mm dia./310m long, breaking load 420kN (42.8t).
- Luffing jib hoist drum.....Optional extra; XP rope with construction of IWRC 6×P·WS (31), 22.4mm dia./225m long, breaking load 420kN (42.8t). Required when luffing towercrane operation.

Liftcrane Capacities 250 metric tons

■ w/0.38m Hammer-head Top Section

Boom length (m) Working radius (m)	15.25	18.30	21.35	24.40	27.45	30.50	33.50	36.55	39.60	42.65	45.70	48.75	51.80	54.85	57.90	60.95	64.00	67.05	70.10	
4.5	250																			
5.0	231	214/5.4	192/5.9																	
6.0	191	190	190	178/6.4																
7.0	164	163	163	163	162	152/7.5														
8.0	144	143	143	143	143	143	135	120/8.5												
9.0	128	128	128	127	127	127	126	119	118/9.1	105/9.6										
10.0	115	115	115	115	115	114	111	108	106	103	93.5/10.1	86.9/10.7	79.0/11.2	70.7/11.7						
12.0	92.3	91.9	95.1	94.7	94.2	92.0	89.7	87.3	85.7	83.4	81.7	79.7	76.4	69.6	63.6/12.2	56.9/12.8	51.1/13.3	42.9/13.8		
14.0	74.3	73.8	77.4	77.1	76.9	76.1	74.7	73.0	71.9	70.0	68.7	67.1	65.6	64.3	60.1	54.8	50.0	42.8	39.9/14.4	
16.0	68.3/14.9	61.5	64.2	63.9	63.6	63.2	63.0	62.1	61.5	60.0	59.0	57.6	56.4	55.3	54.4	51.7	47.1	41.5	38.9	
18.0		54.5/17.5	54.6	54.3	54.0	53.5	53.2	52.8	52.2	51.3	50.1	49.1	48.2	47.5	46.6	44.6	40.4	36.8		
20.0			47.4	47.0	46.7	46.2	46.0	45.5	45.5	45.1	45.1	44.2	43.3	42.5	41.9	41.1	40.2	38.3	34.9	
22.0			46.6/20.2	41.4	41.0	40.5	40.2	39.8	39.8	39.4	39.3	38.9	38.5	37.8	37.2	36.5	35.8	35.0	33.2	
24.0				39.1/22.8	36.4	35.9	35.6	35.1	35.1	34.7	34.6	34.2	34.0	33.8	33.3	32.7	32.0	31.3	30.7	
26.0					33.6/25.5	32.1	31.8	31.3	31.3	30.8	30.8	30.4	30.1	30.0	29.8	29.4	28.8	28.1	27.6	
28.0						29.0	28.6	28.1	28.1	27.6	27.5	27.1	26.8	26.7	26.6	26.4	26.0	25.4	24.9	
30.0						28.8/28.1	26.0	25.4	25.4	24.9	24.8	24.4	24.1	23.9	23.8	23.6	23.4	23.0	22.6	
32.0							25.1/30.8	23.2	23.1	22.6	22.4	22.0	21.7	21.6	21.5	21.2	21.0	20.7	20.5	
34.0								21.8/33.4	21.1	20.6	20.4	20.0	19.6	19.5	19.4	19.2	18.9	18.6	18.4	
36.0									19.4	18.8	18.6	18.2	17.8	17.7	17.6	17.3	17.1	16.8	16.6	
38.0										17.3	17.1	16.6	16.3	16.1	16.0	15.7	15.5	15.2	15.0	
40.0										16.8/38.7	15.7	15.2	14.9	14.7	14.6	14.3	14.0	13.7	13.5	
42.0											14.9/41.3	14.0	13.6	13.4	13.3	13.0	12.8	12.4	12.3	
44.0												12.9	12.5	12.3	12.2	11.9	11.6	11.3	11.1	
46.0													11.5	11.3	11.1	10.8	10.6	10.3	10.0	
48.0														11.2/46.6	10.4	10.2	9.9	9.6	9.3	9.1
50.0															9.9/49.2	9.4	9.1	8.8	8.4	8.2
52.0																8.6/51.9	8.3	8.0	7.7	7.4
54.0																	7.6	7.3	7.0	6.7
56.0																	7.4/54.5	6.6	6.3	6.0
58.0																		6.2/57.2	5.7	5.4
60.0																			5.2/59.8	4.8
62.0																				4.3
64.0																				4.2/62.4

(EC404014)

■ w/9.15m Light-Duty Tapered Top Section

Boom length (m) Working radius (m)	73.15	76.20	79.25	82.30	85.35	88.40
14.0	39.0/14.5	35.4/15.0	31.7/15.5			
16.0	37.5	34.4	31.3	28.3/16.1	26.4/16.5	23.6/17.0
18.0	35.6	32.7	29.7	27.0	25.4	23.0
20.0	33.9	31.1	28.2	25.7	24.1	21.9
22.0	32.4	29.7	26.9	24.5	23.0	20.8
24.0	31.0	28.4	25.8	23.4	22.0	19.9
26.0	29.4	27.1	24.7	22.4	21.0	19.0
28.0	27.3	25.8	23.7	21.4	20.2	18.2
30.0	24.5	24.5	22.6	20.5	19.4	17.5
32.0	22.2	22.1	21.5	19.6	18.5	16.8
34.0	20.1	20.1	20.0	18.7	17.7	16.1
36.0	18.3	18.3	18.2	17.8	16.8	15.4
38.0	16.7	16.7	16.6	16.6	16.1	14.7
40.0	15.3	15.3	15.2	15.2	15.1	14.1
42.0	14.1	14.0	13.9	13.9	13.8	13.5
44.0	12.9	12.9	12.8	12.8	12.7	12.7
46.0	11.9	11.8	11.7	11.7	11.6	11.6
48.0	11.0	10.9	10.8	10.8	10.7	10.7
50.0	10.1	10.0	9.9	9.9	9.8	9.8
52.0	9.3	9.2	9.1	9.1	9.0	9.0
54.0	8.6	8.5	8.4	8.4	8.3	8.3
56.0	7.9	7.9	7.8	7.8	7.7	7.6
58.0	7.3	7.2	7.1	7.1	7.0	7.0
60.0	6.8	6.7	6.6	6.6	6.5	6.4
62.0	6.2	6.2	6.1	6.1	5.9	5.9
64.0	5.8	5.7	5.6	5.6	5.5	5.4
66.0	5.6/64.9	5.2	5.1	5.1	5.0	5.0
68.0		4.9/67.5	4.7	4.7	4.6	4.5
70.0			4.3	4.3	4.2	4.1
72.0			4.2/70.2	3.9	3.8	3.8
74.0				3.8/72.8	3.5	3.4
76.0					3.3/74.8	3.1
78.0						2.9/77.4

(EC404014)

WORKING MASS & GROUND PRESSURE:

Shoe width	Mass	Pressure
1120mm	210.0t	117.2kPa <1.19kg/cm ² >

Note: Working mass shown above is with 15.25m basic boom, 87.7ton counterweight, 14ton carbody weight and optional 250t hook block.

Notes — Liftcrane capacities

1. Capacities included in these charts are the maximum allowable, and are based on machine standing level on firm supporting surface under ideal job conditions.
2. Capacities are in metric tons, and are rated in accordance with prEN13000(2003) & DIN15018/3 Standards; the figures surrounded by bold lines are based on factors other than those which would cause a tipping condition.
3. Capacities are based on freely suspended loads and make no allowance for such factors as the effect of wind, sudden stopping of loads, supporting surface conditions, and operating speeds. Operator must reduce load ratings to take such conditions into account. Deduction from rated capacities must be made for weight of hook block, weighted ball/hook, sling, spreader bar, or other suspended gear.
Hook block weight is as follows:
250t.....3.3ton 200t3.0ton 135t2.6ton
80t.....1.4ton 35t0.8ton 13.5t0.6ton
4. All capacities are rated for 360° swing.
5. Least stable rated condition is over the side.
6. A 93.7ton counterweight and 14.0ton carbody weight are required for all capacities on these charts except the capacities of 15.25m and 18.30m boom which require the deduction of 6ton from the 93.7ton counterweight.
7. Attachment must be erected and lowered over the ends of the crawler mounting.
8. Main boom length must not exceed 88.4m.
Maximum fly jib length permitted — 36.55m.
Maximum boom (with 0.38m hammer-head top section) and fly jib combination length permitted — 70.1m+36.55m.
Maximum boom length (with 0.38m hammer-head top section) when mounting auxiliary short jib is 70.1m.
9. Capacities when handling load off main boom head sheaves in case of mounting fly jib or auxiliary short jib on top of boom are detailed; if required, please consult us or nearest distributor.
10. Boom combination shall be in accordance with manufacturer's standard described here in "Boom Combination Diagram" of page 14.

**SCX2500LF AUXILIARY SHORT JIB CAPACITIES:
Max. 13.5ton**

Note: Jib capacities is almost equal to the figures made by the deduction of approx. 600kg from the liftcrane capacities for boom length up to 70.1m unless restricted by the maximum jib capacity shown above. As to the details, please consult us or nearest distributor.

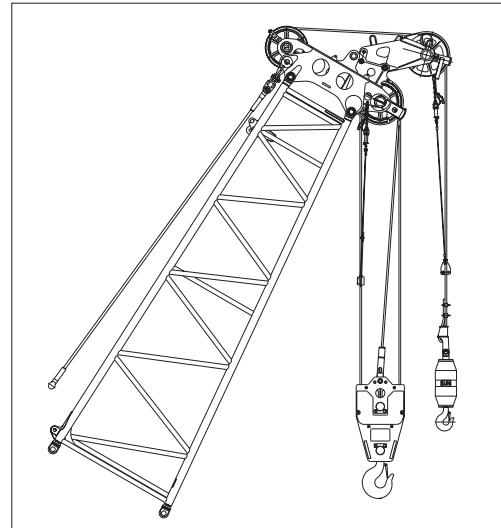

Auxiliary short jib (Option)

Boom length(m)	64.00										67.05										
	12.20		18.30		24.40		30.50		36.55		12.20		18.30		24.40		30.50		36.55		
Jib length(m)	10	30	10	30	10	30	10	30	10	30	10	30	10	30	10	30	10	30	10	30	
Jib offset angle(°)																					
Working radius(m)																					
16.0	27.0/16.8																				
18.0	27.0		24.0/18.9										27.0/17.3								
20.0	27.0	25.8/20.5	23.8			15.5/21.0							26.9		22.8/19.4						
22.0	26.2	25.1	23.0			15.4							25.5	24.0/21.0	22.5			15.4/21.5			
24.0	25.0	24.1	22.0		16.8/24.4	15.1			10.3/23.1				24.3	23.5	21.4			15.4		10.2/23.6	
26.0	24.0	23.2	21.0		16.5	14.8						6.8/25.1	23.2	22.5	20.4		16.7/24.9	15.1		10.2	6.7/25.7
28.0	22.9	22.3	20.2		16.0	14.5		11.5/28.3	9.7				22.1	21.7	19.5		16.5	14.8		9.9	
30.0	21.7	21.4	19.3		15.7	14.2		11.3	9.5				21.2	20.9	18.7		16.1	14.5	11.4/28.8	9.7	6.5
32.0	20.6	20.5	18.6		15.3	13.9		11.0	9.3	8.2/32.2			20.2	20.1	17.9		15.7	14.2	11.3	9.5	6.4
34.0	18.9	19.5	17.8		14.9	13.7		10.7	9.1	8.1			19.2	19.3	17.2		15.3	13.9	11.0	9.3	8.0/32.8
36.0	17.3	18.5	16.9		14.6	13.4		10.5	8.9	7.9	5.9	5.2/36.2	18.1	18.4	16.5		15.0	13.7	10.7	9.1	8.0
38.0	15.6	16.8	16.0		14.3	13.2		10.2	8.7	7.8	5.8	5.1	16.7	17.6	15.7		14.7	13.5	10.5	8.9	7.9
40.0	14.2	15.3	14.7		14.0	12.9		10.0	8.6	7.6	5.6	5.0	16.7	17.6	15.7		14.7	13.5	10.5	8.9	7.9
42.0	12.9	13.9	13.4		13.6	12.5		9.8	8.4	7.4	5.5	4.9	15.3	16.8	14.9		14.4	13.2	10.2	8.8	7.7
44.0	11.7	12.7	12.2		13.1	12.1		9.7	8.3	7.3	5.4	4.8	13.9	15.2	14.1		14.0	12.8	10.0	8.6	7.6
46.0	10.6	11.6	11.1		12.5	11.7		9.5	8.1	7.1	5.3	4.7	12.5	13.9	13.1		13.6	12.3	9.8	8.4	7.4
48.0	9.7	10.6	10.2		11.4	10.7		9.3	8.0	7.0	5.2	4.6	11.4	12.7	11.9		13.1	11.7	9.7	8.3	7.2
50.0	8.8	9.7	9.3		10.5	9.8		9.1	7.7	6.9	5.1	4.5	10.3	11.5	10.8		12.4	11.1	9.5	8.1	7.1
55.0	6.9	7.7	7.3		8.4	7.7		8.4	7.2	6.6	4.8	4.4	9.3	10.5	9.8		11.4	10.4	9.3	8.0	7.0
60.0	5.4	6.2	5.8		6.7	6.1		7.4	6.6	6.3	4.6	4.3	8.5	9.6	8.9		10.4	9.3	9.0	7.8	6.8
65.0	4.2	4.9	4.5		5.3	4.8		5.8	5.1	5.8	4.3	4.2	7.6	8.7	8.1		9.3	8.4	7.1	6.5	5.5
70.0	3.4/68.6	3.9/69.3	3.5		4.2	3.7		4.7	4.0	5.1	3.9	4.0	6.6	7.6	7.0		8.3	7.3	6.3	5.4	4.4
75.0			2.7/74.3		3.2	2.8		3.7	3.1	4.0	3.4	3.7	5.5	6.5	6.1		7.5	6.5	5.5	4.5	3.5
80.0					3.1/75.4	2.0		2.7	2.3	3.1	2.4	3.4	4.4	5.4	5.0		6.6	5.6	4.6	3.6	2.6
85.0						2.0/80.1		2.5/81.5	1.6	1.7	1.7	2.5	3.4	4.4	4.0		5.7	4.7	3.7	2.7	1.7
90.0								1.5/85.8	1.4/87.6	1.1	1.9		2.8	3.7	3.1		4.1	3.1	2.1	1.1	0.1
95.0												1.3/93.7									1.5

(EC404022)

Boom length(m)	70.10									
	12.20		18.30		24.40		30.50		36.55	
Jib length(m)	10	30	10	30	10	30	10	30	10	30
Jib offset angle(°)										
Working radius(m)										
16.0	24.4/17.9									
18.0	24.4									
20.0	23.2	20.9/21.5	20.5							
22.0	22.0	20.7	19.5		15.3					
24.0	21.0	19.8	18.6		16.6/25.5	15.0		10.1/24.1		
26.0	20.1	19.0	17.7		16.5	14.7		9.9		6.7/26.2
28.0	19.2	18.3	16.9		15.8	14.4		11.4/29.4	9.7	6.5
30.0	18.4	17.6	16.2		15.3	14.1		11.3	9.5	6.3
32.0	17.5	17.0	15.5		14.7	13.6		11.0	9.3	7.9/33.3
34.0	16.6	16.3	14.9		14.2	13.1		10.8	9.1	7.9
36.0	15.7	15.7	14.3		13.7	12.6		10.5	8.9	7.8
38.0	15.0	15.0	13.8		13.2	12.1		10.3	8.7	7.7
40.0	13.7	14.3	13.2		12.8	11.6		10.1	8.6	7.6
42.0	12.4	13.3	12.6		12.4	11.2		9.9	8.4	7.4
44.0	11.3	12.1	11.9		11.9	10.8		9.7	8.3	7.3
46.0	10.3	10.9	10.8		11.5	10.3		9.6	8.1	7.2
48.0	9.2	9.8	9.7		10.8	9.8		9.4	8.0	7.0
50.0	8.3	8.9	8.8		9.8	9.3		9.0	7.6	6.9
55.0	6.4	6.8	6.8		7.7	7.1		8.2	7.0	6.6
60.0	4.9	5.2	5.3		6.0	5.4		6.6	6.1	6.2
65.0	3.6	3.8	4.0		4.5	4.1		5.1	4.7	5.6
70.0	2.6	2.8	2.9		3.4	3.3		3.9	3.6	4.4
75.0	1.9/73.9	1.8/74.6	2.0		2.2	2.3		2.8	2.6	3.3
80.0					1.4	1.5		1.9	1.8	2.3
85.0								1.1	1.8	1.2
90.0										1.1

(EC404022)

Notes — Fly jib capacities

- Capacities included in these charts are the maximum allowable, and are based on machine standing level on firm supporting surface under ideal job conditions.
- Capacities are in metric tons, and are rated in accordance with prEN13000(2003) & DIN15018/3 Standards; the figures surrounded by bold lines are based on factors other than those which would cause a tipping condition.
- Capacities are based on freely suspended loads and make no allowance for such factors as the effect of wind, sudden stopping of loads, supporting surface conditions, and operating speeds. Operator must reduce load ratings to take such conditions into account. Deduction from rated capacities must be made for weight of hook block, weighted ball/hook, sling, spreader bar, or other suspended gear. Hook block weight is as follows:
35t.....0.9ton 13.5t.....0.6ton
- All capacities are rated for 360° swing.
- Least stable rated condition is over the side.
- A 93.7ton counterweight and 14.0ton carbody weight are required for all capacities on these charts except the capacities of 15.25m and 18.30m boom which require the deduction of 6ton from the 93.7ton counterweight.
- Attachment must be erected and lowered over the ends of the crawler mounting.
- Main boom length must not exceed 88.4m. Maximum fly jib length permitted — 36.55m. Maximum boom (with 0.38m hammer-head top section) and fly jib combination length permitted — 70.1m+36.55m. Maximum boom length (with 0.38m hammer-head top section) when mounting auxiliary short jib is 70.1m.
- Capacities when handling load off main boom head sheaves in case of mounting fly jib or auxiliary short jib on top of boom are detailed; if required, please consult us or nearest distributor.

Liftcrane Working Ranges

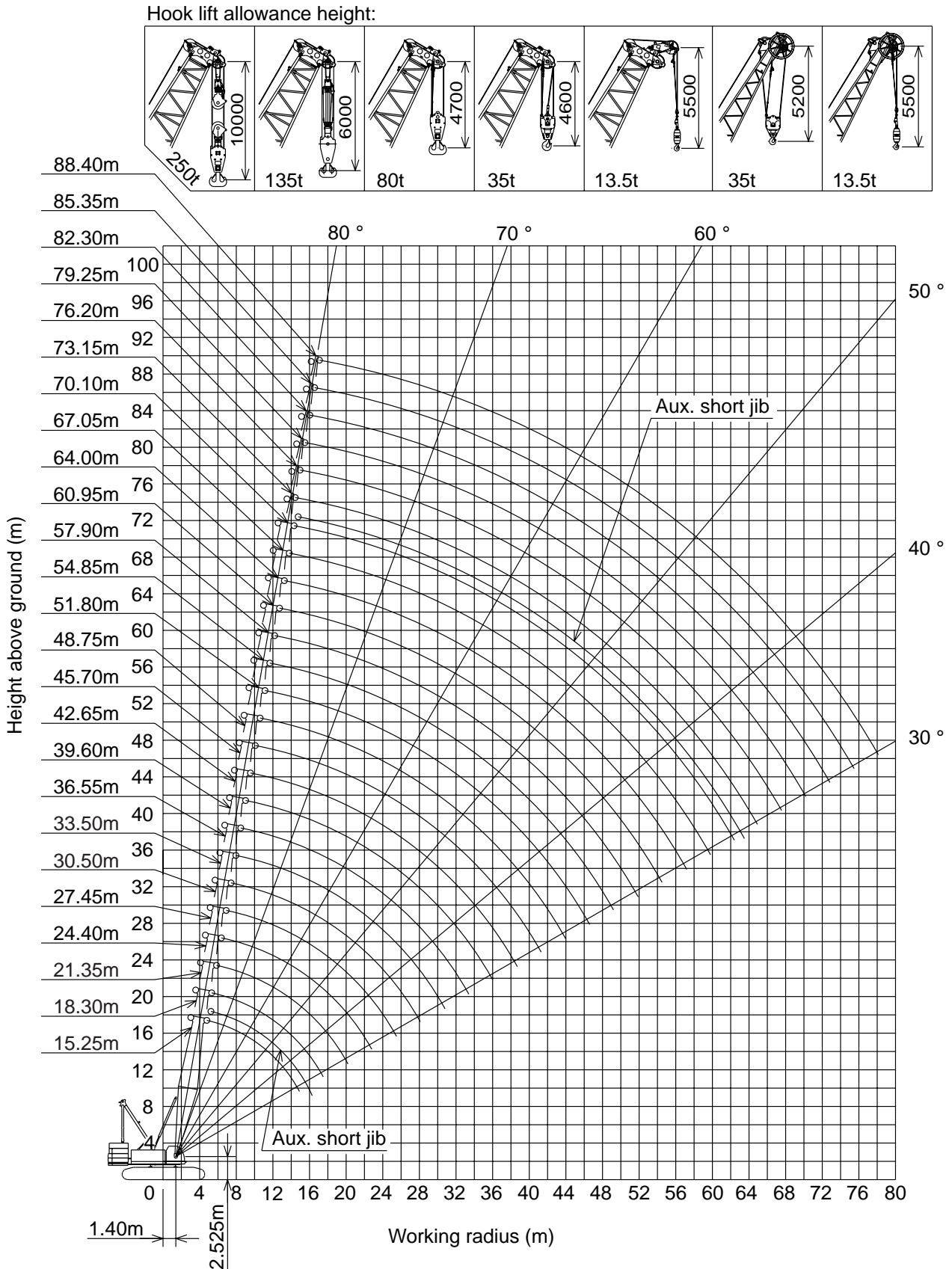

Note: This diagram just shows working ranges under 88.40m boom length as max. without fly jib.

Boom Combination Diagram

Boom length (m)	Boom combination
15.25	
18.30	
21.35	
24.40	
27.45	
30.50	
33.50	
36.55	
39.60	
42.65	
45.70	
48.75	
51.80	
54.85	
57.90	
60.95	
64.00	
67.05	
70.10	
73.15	
76.20	
79.25	
82.30	
85.35	
88.40	

Notes: 1. Fly jib can be mounted on main boom ranging all the way from 45.75m thru 70.10m with a 0.38m hammer-head top section.
 2. The other combination for each boom length except 3 kinds of boom lengths of 15.25m/18.30m/70.10m shall be available. If required, please consult us or nearest distributor.
 3. The boom combination diagram here shows that the 9.15m ultra and 6.10m heavy-duty boom extensions with bridle rest are used in a consideration of converting luffing towercrane booms to liftcrane booms. If liftcrane attachment is only required, these two boom extensions don't require the bridle rest.

Note:

The meanings of figures and symbols shown above are as follows:

- : 7.62m heavy-duty bottom section
- : 7.24m heavy-duty tapered extension plus 0.38m hammer-head top section
- : 9.15m heavy-duty boom extension
- : 9.15m ultra heavy-duty boom extension
- : 9.15m ultra heavy-duty boom extension w/bridle rest (See item 3 of Notes shown above)
- : 6.10m heavy-duty boom extension w/bridle rest (See item 3 of Notes shown above)
- : 3.05m heavy-duty boom extension
- : 4.55m tapered boom extension
- : 9.15m light-duty boom extension
- : 6.10m light-duty boom extension
- : 3.05m light-duty boom extension
- : 9.15m light-duty tapered top section
- * : Midpoint link installing position; it is required to install midpoint link when boom length is 73.15m and over.

General Dimensions

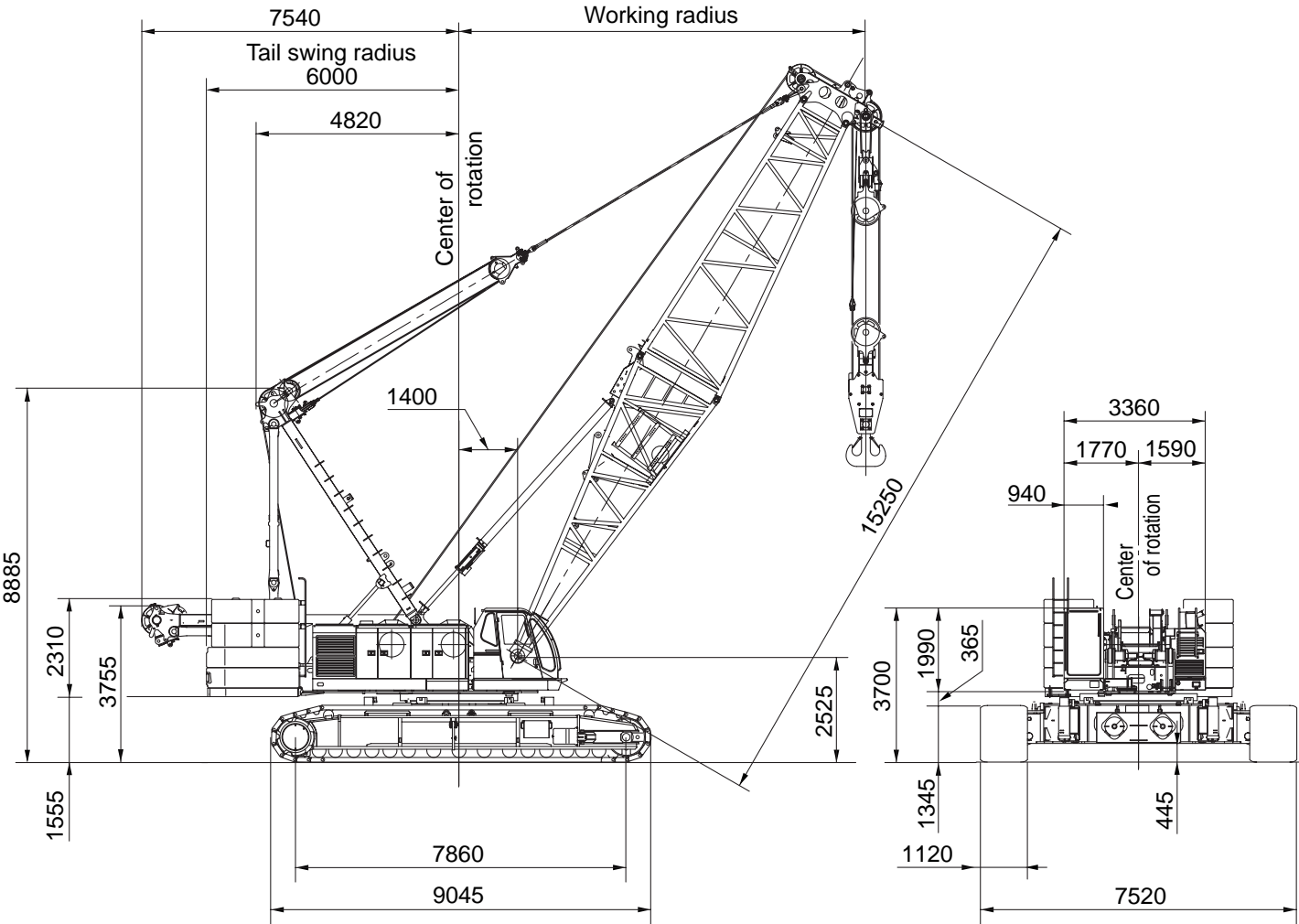

(in mm)

Note: The above general arrangement is under liftcrane application with 15.25m basic boom, and optional 250t hook block.

Standard and Optional Equipment

	Standard equipment	Optional equipment
Superstructure	<ul style="list-style-type: none"> ● Mitsubishi 6D24-TL diesel engine with a 235kW <320ps> rated output; ● Hydraulic system with three variable displacement axial piston pumps and one fixed displacement duplicate tandem gear pump; provided with an independent oil cooler; ● Control system with two sets of triplicate tandem valves and pilot-operated arm chair single axis control levers; ● Motorcycle type "SC" controller (easy-precise-minute engine rpm and hyd. pump oil flow control device); ● Front and rear main operating drum winches of 25ton line pull with 576mm dia. drum lagging driven by independent variable hyd. motor with independent hyd. circuit; each provided with automatic brake; ● Boom hoist mechanism with a twin-drum design driven by two hyd. motor with automatic brakes; ● Swing mechanism with heavy-duty turntable bearing; driven by two hyd. motors w/spring-applied, power hydraulically released multiple wet-disc brakes; ● Power hydraulically retractable A-frame gantry; ● All new stamped, automotive type, full-vision operator's cab with large curved front window; provided with an arrangement of armchair operator control station and instrument panel; ● 93.7ton counterweight; ● Machinery cab with hinged doors; ● 24-volt electrical system with two 12-volt batteries; ● Lighting system: <ul style="list-style-type: none"> • Two 70W working lights; • One 10W interior cab light; ● Anemometer; ● Accessotes: <ul style="list-style-type: none"> • AM/FM radio w/clock; • Engine hourmeter; • Engine tachometer; • Fuel gauge; • Thermometer; • Hyd. oil temp. gauge; • Pilot line pressure gauge; • Foot throttle; • Intermittent dual window shield wipers with washers; • Cigar lighter; • Ash tray; • Book holder; • Sunvisor; • Sunshade; • Cup holder; • Non-skid surfaces; • Cab front step; • Cab floor mat; • Superstructure under-cover. ● Std. spare parts and tools. 	<ul style="list-style-type: none"> ● Hydraulic tagline winder; ● Drum rollers; available on front/rear main; ● Stone guard; this is for operator's cab; ● Fire extinguisher; ● Catwalks, along both sides of machinery cab; ● Built-in type full air-conditioning; ● Re-fuel pump; ● Heater; ● External contracting band brakes and clutches; required instead of standardized automatic brake in case that a true gravity free-fall function is necessary on front/rear main drums; ● Portable engine-hydraulic power pack; required when luffing towercrane att.

	Standard equipment	Optional equipment
Undercarriage	<ul style="list-style-type: none"> ● 6,400mm gauge by 9,045mm long crawler lower with removable crawler side frames; provided with four of tip blocks with pins, lugs and hyd. joint-pin removal cylinders; ● Crawler drive units with shoe-in type traction motor with wet-disc type automatic brakes; ● 1,120mm wide track shoes; ● Manual track tension adjusting devices; ● Carbody jack-up device w/4-vertical hyd. jack-up cylinder and remote control unit; ● 14ton carbody weight; ● Lifetime lubricated track components; ● Crawler side steps. 	<ul style="list-style-type: none"> ● Automatic track tension adjusting device, i/o manual one as std.
Liftcrane Att.	<ul style="list-style-type: none"> ● 15.25m basic crane boom; 7.62m bottom section, 7.24m heavy-duty tapered extension and 0.38m hammer-head top section w/five head sheaves, and two guide sheaves; provided with boom foot pin removal cylinders; ● Bail and bridle assemblies; ● Main crane hoist cable; 28mm dia./410m long; ● Boom hoist cable; 22.4mm dia./310m long; 	<ul style="list-style-type: none"> ● 3.05m heavy-duty boom extension; ● 6.10m heavy-duty boom extension (w/bridle rest); ● 9.15m heavy-duty boom extension; ● 9.15m ultra heavy-duty boom extension; ● 9.15m ultra heavy-duty boom extension (w / bridle rest); ● 4.55m tapered boom extension; ● 3.05m light-duty boom extension; ● 6.10m light-duty boom extension; ● 9.15m light-duty boom extension; ● 9.15m light-duty tapered top boom; ● 12.20m basic fly jib; 6.10m bottom and top sections with jib strut and boom/jib quylene pendants; ● 6.10m fly jib extension; ● Auxiliary short jib; ● 250/135t with a 5-hanger sheave block; ● 200/135t with a 3-hanger sheave block; ● 135t hook block; ● 80t hook block; ● 35t hook block; ● 13.5t ball hook; ● Five-hanger sheave block (pinned to boom head shaft of 0.38m hammer-head top section); required together with 250t hook block when lifting load exceeds 135ton, and available up to 250ton lift; ● Three-hanger sheave block (pinned to boom head shaft of 0.38m hammer-head top section); required together with 200t hook block when lifting load exceeds 135ton, and available up to 200ton lift. ● Aux. crane hoist cable, 28mm dia./290m long; available for fly jib application; ● Aux. crane hoist cable, 28mm/150m long; available for aux. shart jib application; ● Aux. crane hoist cable, 28mm dia./410m long; available for luffing jib application; ● Boom skywalk; available for all sections of lificrane main boom.

	Standard equipment	Optional equipment
Luffing Towercrane Att.		<ul style="list-style-type: none"> ● A 0.38m tower head section; provided with two rope guide nylon sheaves; ● A 8.9m front post with a 4-nylon sheave machinery; ● A 7.3m rear post with a 4-nylon sheave machinery; ● A 9.15m jib bottom section; ● Optional a 3-nylon sheave machinery provided on a part of 9.15m jib bottom section; ● 6.10m tower boom extension with bridle rest; ● 9.15m ultra heavy-duty tower boom extension with bridle rest; ● 9.15m heavy tower jib extension; ● A nylon guide sheave for jib hoist cable pinned to a part of 7.24m heavy-duty tapered extension; ● Optional mid-point suspension cable; required when tower jib length exceeds 51.80m; ● Rear post pendant ropes with ajustable links; ● Luffing jib hoist winch drum; ● Luffing jib hoist winch drum cable, 22.4mm dia. by 225m long; ● Towercrane hoist cable, 28mm dia./410m long (as same as main crane hoist cable of liftcrane att.); towercrane hoist must, however, be by rear main drum; ● Tower boom hoist cable, 22.4mm/310m long (as same as boom hoist cable of liftcrane att.); ● 80t hook block (as same as an optional 80t hook block of liftcrane att.); ● 35t hook block (as same as an optional 35t hook block of liftcrane att.); ● 13.5t ball hook (as same as an optional 13.5t ball hook of liftcrane att.). <p>Notes:</p> <ol style="list-style-type: none"> 1. Boom bottom section of 7.62m, heavy-duty tapered extension of 7.24m, heavy-duty boom extensions of 3.05m/ 6.10m/ 9.15m and ultra heavy-duty boom extension of 9.15m as necessary to complete tower boom are available from those of liftcrane att. 2. Tower jib extensions of 3.05m, 6.10m and 9.15m and tower jib top section of 9.15m are same as those of light-duty boom extensions of 3.05m, 6.10m and 9.15m, and light-duty tapered top section of 9.15m of liftcrane att.
Safety Devices	<ul style="list-style-type: none"> ● SML-10 Load Moment Limiter; this is a computerized automatic over-load preventing system with an all-machine-control purpose computer; ● Some kinds of warning alarms; ● Drum rope over-payout preventing device; ● Main and aux. drum pawl locks; ● Boom hoist drum pawl lock; ● Swing lock; ● Swing alarm; ● Hook over-hoist limiting device; ● Boom over-hoist and -lowering limiting device; ● Dual boom over-hoist limiting device; ● Boom backstops; ● Speed slowdown device; ● Boom angle indicator; ● Level gauge; fitted on floor of operator's cab and a part of undercarriage; ● Swing brake lamp; ● Signal horn; ● Travel alarm; ● Hook latch; ● Control lever locks; ● Fool proof shut-off system; ● Engine monitoring lamps; ● Rear view mirrors; ● Emergency machine stop buttons. 	<ul style="list-style-type: none"> ● Aux. hook over-hoist limiting device; ● Lifting height meter; ● Three color percentage indicator; ● Microphone & loud-speaker; ● Drum light & mirror. <p>Followings are standard in case of luffing tower-crane attachment:</p> <ul style="list-style-type: none"> ● Luffing jib angle detector; ● Luffing towercrane load detector; ● Luffing jib hook over-hoist limiting device; ● Luffing jib over-hoist and -lowering limiting device; ● Luffing towercrane att. self-erection mode; ● Luffing jib hoist drum pawl lock (w/automatic pawl-locking device); ● Luffing jib backstops; ● Dual Luffing jib over-hoist limiting device; ● Rear post backstops (hyd. cylinder type).

MEMO

A series of horizontal dotted lines for writing.

Hitachi Sumitomo Heavy Industries Construction Crane Co., Ltd.

12-14, Ueno 7-chome, Taito-ku, Tokyo 110-0005, Japan

Phone: 81-3-3845-1387 Facsimile: 81-3-3845-1394

- We are constantly improving our products and therefore reserve the right to change designs and specifications without notice.
- Units in this specification are shown under International System of Units; the figures in parenthesis are under Gravitational System of Units as old one.

Address Inquires to: